



Clay Electric Cooperative, Inc.

A Touchstone Energy® Cooperative 

**STANDARDS
FOR
ELECTRIC SERVICE**

**CLAY ELECTRIC COOPERATIVE, INC.
KEYSTONE HEIGHTS, FLORIDA
(352) 473-8000**

DISTRICT OFFICES

Gainesville

(352) 372-8543

Lake City

(386) 752-7447

Keystone Heights

(352) 473-4917

Orange Park

(904) 272-2456

Salt Springs

(352) 685-2111

Palatka

(386) 328-1432

Revised 4/08/2026

INTRODUCTION TO
STANDARDS FOR ELECTRIC SERVICE

The Standards for Electric Service is presented to acquaint architects, developers, engineers, contractors, and members with requirements for receiving electric service.

These service standards are not intended to conflict in any manner with the National Electrical Code, the National Electrical Safety Code, or other State, County, or Cities' electrical code, but are intended to supplement these codes and to clarify certain service requirements which have been found from experience to be best for maintaining safe, satisfactory and good service to the members. It is not expected that this book of standards will cover in detail all of the conditions that arise with the many combinations possible in the construction of electric service installations. The illustrations offered are typical and intended to show the most important points in construction. Where conditions arise that this book does not cover, a representative of Clay Electric Cooperative, Inc., may be contacted to aid the member.

The Clay Electric Cooperative District Offices, listed on the title page, will be glad to assist you with your request for new services, changes in existing services, or additions of new loads to existing installations.

Yours truly,

Richard K. Davis
General Manager & CEO

TABLE OF CONTENTS
STANDARDS FOR ELECTRIC SERVICE

<u>Introduction</u>	<u>Page No.</u>
Definitions	6
<u>Section 1 General Information</u>	
1.01 Application for Electric Service	7
1.02 Service Connection	7
1.03 Availability of Service	7
1.04 Line Extension Charges	8
1.05 Temporary Service	10
1.06 Standby Service	11
1.07 Signs on Federal Financed Roads	11
1.08 Limits of Cooperative Liability	11
1.09 Inspection	12
1.10 Member Use of Cooperative's Facilities	12
<u>Section 2 Developments</u>	
2.01 General	13
2.02 Extension of Electric Facilities	13
2.03 Development Coordination	13
2.04 New Right of Way Clearing	15
<u>Section 3 Type and Characteristics of Electric Service</u>	
3.01 Types and Characteristics of Electric Service	17
3.02 Type of Electric Service	17
3.03 Service Voltage Limits	17
3.04 Neutral Voltage	18
<u>Section 4 Secondary Service - Overhead</u>	
4.01 Member's Service Entrance	19
4.02 Service Drops - Number per Building	20
4.03 Service Drops - Clearances	20
4.04 Service Drop - Anchorage	21
4.05 Service Drop - Connectors	21
4.06 Services Larger than 600 Amps	21
4.07 Grounding	21

Section 5 Secondary Service - Underground

5.01	Service Entrance Requirements	22
5.02	Residential; Single Phase Underground	22
5.03	Underground Commercial	24

Section 6 Meter Installations

6.01	Meter Location	27
6.02	Identification of Meters	28
6.03	Single Phase Meter Installations	28
6.04	Four-Wire, Three Phase Meter Installations	28
6.05	Instrument Transformer Installations	29
6.06	Impulse Metering for Large Services	29
6.07	Time-of-Use Metering	29

Section 7 Primary Service

7.01	General	30
7.02	Metering	30
7.03	Cooperative Equipment behind Meter	30

Section 8 Member Utilization Equipment

8.01	General	31
8.02	Motors	31
8.03	Special Equipment	31
8.04	Member Owned Generators	32
8.05	Harmonics	33
8.06	Interconnection Guidelines of Member-Owned Distributed Generation	33

Section 9 Maintenance of Service

9.01	Alterations and Additions	35
9.02	Protection by Member of Cooperative's Property	35
9.03	Right of Entry	36
9.04	Easement Restrictions	36

Section 10 Outdoor Lighting Service

10.01	General	37
10.02	Public Roadway Lighting	38
10.21	Subdivision Roadway Design Standard	39
10.22	Public Roadway Intersection Lighting	40
10.23	Crosswalk/Bus Stop Lighting	40
10.03	Residential Outdoor Lighting	40
10.04	Public/Commercial Outdoor Lighting	41

Appendix

Figures

A1	Neutral Voltage Checklist	A
A2	Motor Start Form	B
A3	Service Installation Drawings	1-7A
A4	Meter Socket Wiring Diagrams	8-14
A5	CT Meter Installations	15-18A
A6	CT Meter Enclosure	19, 19A
A7	Combination Meter Enclosures	20-21
A8	Member Owned Generators	22
A9	Roadway Lighting Guidelines	23-26

Definitions

Accessible:

Capable of being reached quickly without requiring the adjustment or removal of obstacles; not being closely enclosed by fences, hedges, or other obstacles, which prevent or hinder approachability.

Code:

The National Electric Code, NFPA No. 70; the National Electrical Safety Code, ANSI No. C2; State or local codes having jurisdiction over an electrical installation.

Member:

Any present or prospective user of electric service from the Cooperative or his authorized representative - architect, engineer, contractor, etc.

Cooperative:

Clay Electric Cooperative, Inc.

District Office:

An office of the Cooperative located in one of the six district service areas.

Load:

The member's equipment requiring electrical power: The quantity of electric power required usually expressed in amperes, kilowatt (kW), or kilovolt - amperes (kVA).

Primary:

These are the main feeder circuits extending from the Cooperative's substation to the general vicinity of the member's point of service. Primary voltages are either 7,200/12,470 or 14,400/24,900 Volts.

Secondary:

This is the portion of the Cooperative system that extends from the Cooperative's distribution transformer to the service drop. Secondary voltages are usually 120/240 Volts but may be as listed in Paragraph 3.022.

Service:

The supply of electric energy to a member; the wire connecting the Cooperative's wiring to the member's wiring.

Service Drop:

The overhead service conductors between the Cooperative's pole and the member's point of attachment.

Service Entrance:

Wires and enclosures connecting the member's service equipment to the Cooperative's service drop or other source of supply.

SECTION 1

GENERAL INFORMATION

1.01 Application for Electric Service

An application for permanent service must be made by the member as far in advance of their occupancy as possible.

Each applicant for service must complete and sign an "Application for Membership and for Electric Service", for each individual service requested. Identification of the person responsible for the charges is required.

All new service requests are subject to the availability of material!

1.02 Service Connection

1.21 Each individual service connection shall be metered and billed separately. Each dwelling shall be treated as an individual service connection. Each individual mobile home shall be treated as an individual service connection. Out buildings, pumps, etc., may be supplied from a meter on any individual service connection as described above.

1.22 Connection of services to and disconnection from the Cooperative's system (including temporary services) shall be carried out by Cooperative personnel only. With prior approval from the Cooperative, licensed electricians are permitted to disconnect service drops in order to perform necessary work on service entrance and equipment. In these instances, the Cooperative will reconnect the service drop after any required County inspections.

1.03 Availability of Service

1.31 Information may be obtained at the local district office as to the availability of service at the location where it is desired. The Cooperative will make extensions to its existing facilities when required, provided the revenue to be derived shall be sufficient to afford a fair and reasonable return on the cost of making such extensions.

1.32 The Cooperative will provide service in the most economical way possible. If, at the member's request and for their benefit, the Cooperative's facilities are designed and constructed in a way which is not the most economical, the member shall be required to pay the cost differential between the two. This shall include the additional cost of materials, labor and overhead and shall be paid prior to construction of any facilities.

1.33 Three-phase power is not available in every part of the service area, especially in rural areas served underground or in isolated urban areas. Therefore, contact should be made with the Cooperative for service availability before specifying and purchasing equipment or wiring of buildings for three-phase equipment or motors of any size.

- 1.34 A combination of a minimum of 10 horsepower, with at least one motor 5 horsepower or larger is required for three-phase service to be extended.
- 1.35 Timely request for service location shall be made by the member at the nearest Cooperative District Office before construction is started. This request for service is not an application for service to the completed building.
- 1.36 The Cooperative will provide service to public or private airports in accordance with paragraph 1.031 above. However, in so providing service, the Cooperative will not build overhead lines across runways or taxiways. If member requires service across runways or taxiways the member shall pay for such service to be placed underground in accordance with formula as set forth in paragraph 5.022D.
- 1.37 The Cooperative reserves the right to refuse overhead service to areas deemed unsafe or impractical for overhead facilities. If the member requires service in these areas, the member shall pay for such service to be placed in conduit underground in accordance with the formula as set forth in paragraph 5.022D.
- 1.38 The Cooperative's distribution facilities both overhead & underground will be located along public/private road rights-of-way whenever possible to provide for the greatest accessibility for maintenance and operation.

1.04 Line Extension Charges

1.41 General

Line extension charges are designed to allow the Cooperative to have a reasonable assurance that adequate revenue will be provided by a new member to give a fair rate of return on the investment cost of the new transmission or distribution facilities required to serve the member.

These extension charges are based on overhead extensions. Underground extensions are handled as set forth in Section 5.

1.42 Commercial Member (Demand)

Facilities to provide electric service to a new commercial member except those with a small load or infrequent use shall be furnished by the Cooperative at a cost to the member, if any, as determined by the line extension formula.

The following line extension formula shall be used to determine the contribution in aid of construction owed by member.

$$\begin{aligned}
\text{CIAC}_{\text{OH}} = & \quad (\text{Actual or estimated job cost} \quad) \\
& \quad (\text{for new poles, conductors} \quad) \\
& \quad (\text{and appropriate fixtures required} \quad) \\
& \quad (\text{to provide service, excluding} \quad) \\
& \quad (\text{transformers, service drops,} \quad) \\
& \quad (\text{and meters} \quad) \\
- & \quad (4X \text{ nonfuel energy charge per} \quad) \\
& \quad (\text{kWh X expected annual kWh} \quad) \\
& \quad (\text{sales over the new line} \quad) \\
- & \quad (4X \text{ expected annual demand} \quad) \\
& \quad (\text{charge revenues from sales} \quad) \\
& \quad (\text{over the new line} \quad)
\end{aligned}$$

This contribution in aid of construction is a one-time charge, which must be paid before construction is begun on the line extension and shall be non-reimbursable.

1.43 Residential and Small Commercial (Non-Demand)

Facilities to provide service to new residential or small commercial members shall be furnished by the Cooperative at a cost, if any, as determined by the line extension formula. Right of way clearing will not be absorbed by the Cooperative for these applications described above.

The following line extension formula shall be used to determine the contribution in aid of construction owed by member.

$$\begin{aligned}
\text{CIAC}_{\text{OH}} = & \quad (\text{Actual or estimated job cost} \quad) \\
& \quad (\text{for new poles, conductors} \quad) \\
& \quad (\text{and appropriate fixtures required} \quad) \\
& \quad (\text{to provide service, excluding} \quad) \\
& \quad (\text{transformers, service drops,} \quad) \\
& \quad (\text{and meters} \quad) \\
- & \quad (4X \text{ nonfuel energy charge per} \quad) \\
& \quad (\text{kWh X expected annual kWh} \quad) \\
& \quad (\text{sales over the new line} \quad)
\end{aligned}$$

This contribution in aid of construction is a one-time charge, which must be paid before construction begins on the line extension and shall be non-reimbursable. At a residential member's request, the Cooperative may finance the line extension charge for a period of one (1) to seven (7) years at an appropriate annual interest rate. This monthly rate will then be added to the normal monthly charge for electricity until paid in full plus interest. Financing will be for not less than \$1000 or more than \$7500 and the term of financing will be adjusted based on the amount financed.

If a member chooses the monthly charge and, at some time up to the seven (7) year period, service to a second member is provided from the same line extension, the existing line shall be considered an "existing line" for the purpose of any calculations for the new member.

The new member shall pay line extension charges only for new lines constructed exclusively to serve their location, and this will be calculated as described in Section I.

The line extension charge applied to the existing member will be removed if the original extension to the existing member was less than one (1) mile (5,280 feet) and the second or new member has estimated usage greater than 10,000 kWh per year (833 kWh per month). If the extension was longer than one (1) mile or the estimated usage is less, a proportional amount of the charge should be removed.

1.05 Temporary Service

1.51 Temporary Service for Construction Purposes

No charge, except for a connect fee, will be required for the installation of a single phase temporary service for construction purposes when the installation of only a service drop is involved. When other construction, such as the installation of lift poles, transformers, etc., is required for the temporary service and will be retired when the temporary service is disconnected, the cost of construction and retirement of these temporary facilities will be charged and shall be collected before beginning work. Charges for temporary service for construction purpose shall not include the cost of any facilities, which shall become permanent.

1.52 Temporary Service for Community Service

No charge for connecting or for electricity used is made to a community civic body when used for only two days or less. Examples of this type of service are for voting booths, special suppers, or entertainment for a community.

1.53 Temporary Service for Commercial Purpose

When special temporary service is requested for a carnival, truck trailer shows or other similar commercial purposes, the Cooperative's cost of construction and retirement of the service, plus a deposit for the estimated electric bill must be secured before beginning work on installing the electric service.

1.54 Inspection of Member's Temporary Facilities

Service entrance, meter, and other wiring for temporary installations shall be made and inspected in the same manner as permanent installations.

1.06 Standby Service

The Cooperative will extend to a member an electric service, which is to provide an alternate source of electricity on a standby basis, i.e. the Cooperative's service to the member is not the normal source of electric power. The cost of such extension including the material and the labor to install and remove the required facilities shall be paid in full by the member prior to work being started. The monthly charge for a standby service shall be contracted on an individual basis to insure a reasonable return to the Cooperative on its investment to provide this service. If a member is receiving service from the Cooperative as the normal source and desires a second source from the Cooperative, the second source shall be handled as a standby service.

1.07 Signs on Federal Financed Roads

The Cooperative will extend service to a sign in accordance with paragraph 1.043 above. The member will be required to pay for the electricity used under the General Service, Non-Demand rate for all signs.

The member will be required to sign a contract for a minimum on the General Service, Non-Demand rate for all signs.

An approved sign permit shall be presented to the Cooperative prior to any construction by the Cooperative.

1.08 Limits of Cooperative's Liability

The Cooperative will use reasonable diligence at all times to provide dependable service at the nominal voltage but does not guarantee nor will it be liable to the member for complete or partial failure or interruption of service or fluctuation in voltage or for phase failure or reversal.

The Cooperative shall not be liable for any condition caused directly or indirectly by mechanical failure of equipment and/or facilities, by repairs or adjustments to its system or for want of supply or by riots, strikes, civil unrest, insurrections, accident litigation, interference by Federal, State or Municipal Governments, acts of God, acts of the public enemy, or any cause beyond the Cooperative's control.

After the electric energy passes the metering equipment of the Cooperative it becomes the property of the member and the Cooperative shall not be liable for loss or damage to any person or property whatsoever resulting directly or indirectly from the use, misuse, or presence of said electric energy on the member's premises.

Protection of motors against under voltage, overcurrent, phase failure or reversal and short circuit is the responsibility of the member.

1.09 Inspection

The wiring and equipment of the member shall be installed and maintained in accordance with the latest edition of the National Electrical Code and local requirements.

All wiring installations shall be inspected and approved by an authorized inspector before the installation is connected. Where such inspection is required by law, the Cooperative will make connection only after approval by the authorized inspecting authority.

The Cooperative reserves the right to refuse service to any new installation or disconnect service to any existing installation that is unsafe and not in accord with code standards. The Cooperative will not be responsible for defective wiring or defective equipment of the member or damage resulting from such defects.

Prior to energizing a new service or cutting on an existing service the safety of the wiring shall be verified using a Cooperative approved meter socket tester. If the tester indicates a wiring problem, the meter shall not be set and the member notified that there is a problem.

1.10 Member Use of Cooperative's Facilities

Member owned facilities shall not be permitted on the Cooperative's poles or other equipment.

SECTION 2

DEVELOPMENTS

2.01 General

A residential development shall be a single family development with twelve or more lots, a multifamily development with six or more units, or a mobile home park of twelve or more units where lots are relatively small and are rented or leased by one owner.

2.012 A commercial development shall be a project under one ownership consisting of three or more meter points utilized predominately for non-residential purposes.

2.013 A complete set of plans for the development shall include the following:

1. Name, address and phone number of person responsible for the development
2. Registered survey including lots and right-of-way
3. Proposed water distribution
4. Proposed sanitary sewer system
5. Proposed storm drain and ponds
6. Proposed curb and gutter, edge of pavement, and road centerlines
7. Construction plans including electrical and load requirements - commercial and multifamily
8. Electronic set of plans should include the following:
 - CAD file in AutoDesk/AutoCad.dwg format
 - Any Layers shall be imbedded in the .dwg file and capable of editing.
 - CAD drawing should be spatially accurate with NAD 1983 State Plane Florida North FIPS 0903 Feet being the preferred coordinate system.

2.02 Extension of Electric Facilities

The Cooperative will extend a distribution line to an area being developed in accordance with Section 1. When an underground extension is required to reach an area being developed, a cost difference between overhead and underground will be charged as described in Section 5. The cost shall be paid with a certified or cashiers check made payable to Clay Electric Cooperative, Inc., and payment shall be made prior to the beginning of any construction.

2.03 Development Coordination

2.31 A preconstruction conference shall be held as soon as possible after the developer and the Cooperative have agreed upon service to the subdivision. The purpose of the conference is to avoid costly construction conflicts and delays in completion dates caused by the lack of overall coordination and understanding of each company's responsibilities and policies. It shall be the developer's responsibility to coordinate the work and to advise the Cooperative as necessary

for it to carry out its responsibilities as agreed upon at the preconstruction conference. It shall be the developer or general contractor's responsibility to assure the attendance of the representatives of all utilities and contractors at the preconstruction conference.

- 2.32 The developer shall be responsible for identifying lot corners and other necessary boundaries required for the Cooperative to locate its facilities within the development. Lot corners shall be marked with a metal stake or other previously accepted means. In an existing development, when the developer is unavailable, the applicant for service may be asked to locate his property corner.
- 2.33 Once a satisfactory route has been arrived upon, utility easements must be obtained across all portions of said route under private ownership, prior to the beginning of construction activities.
- 2.34 When underground electric service is extended, prior to the installation of curb and gutter and/or paving of the streets and in conjunction with the preparation of the sub grade, the developer shall notify the Cooperative that the street sub grade is being completed and the necessary property markers are installed. Any work required above normal construction practices by the Cooperative will be at the expense of the developer.
- 2.35 When served by underground electric, it shall be the developer's responsibility to have the URD cable route cleared and graded to rough grade (\pm 6 inches), a final grade established, and a conduit system furnished for both the primary and secondary cables in accordance with Cooperative specifications. The specifications of the conduit system will be distributed at the utility preconstruction meeting. The installation and integrity of the conduit is the responsibility of the developer until such time that the Cooperative has successfully installed cable in the conduit. Any work required, above normal construction practices, by the Cooperative will be at the expense of the developer. Once the Cooperative has successfully installed cable in the conduit, the conduit along with any fittings, shall become the sole property of the Cooperative at no charge to the Cooperative. Should the grade be changed after the cable has been pulled into the conduits and the transformers and hand vaults set, the developer shall bear the cost of the adjustments. When all required fees have been paid, documents and easements secured, the right of way has been cleared, rough grade finished, conduits installed, and the property corners along the proposed cable route have been properly marked, the Cooperative shall be notified and construction will be started as soon as possible.
- 2.36 The Cooperative primary method of installation is to pull cable into developer installed conduit. Should the Cooperative decide that this is not feasible, open trenching installation method will be implemented. If the Cooperative encounters obstacles to productive trenching such as a rock subsoil the Cooperative will stop trenching construction and determine if the obstacle is sufficient to stop underground construction or if additional aid-to-construction will be required to proceed. The Cooperative will require approval of the developer on plan of action or additional cost before proceeding. The developer will be responsible for supplying and installing all street crossing conduits in accordance with

Cooperative specifications. The installation and integrity of the conduit crossing is the responsibility of the developer until such time that the Cooperative has successfully installed cable in the conduit. Any work required above normal construction practices by the Cooperative will be at the expense of the developer. Once the Cooperative has successfully installed cable in the conduits, the conduits, along with any fittings, shall become the sole property of the Cooperative at no charge to the Cooperative.

2.04 New Right of Way Clearing

2.41 New right of way in a development to be served overhead:

In all new developments, the developer shall clear right of way to Cooperative needs along with road clearing and land clearing operations. In established developments, the developers will be requested to clear right of way to Cooperative needs along with his road clearing and land clearing operation. If it is already past this stage before the Cooperative gets application and Cooperative has to clear right of way, the Cooperative will leave debris in as orderly a fashion as possible by windrowing or, if absolutely necessary, by cutting trunks into lengths that can be handled (6 feet).

2.42 New right of way involving individual property owners:

The Cooperative, at the time of obtaining easements or designing primary line, will work with the property owner to establish route with the least tree removal or trimming impact. The Cooperative's goal is to minimize tree removal and trimming. The Cooperative's goal is also not to remove all debris but leave it in as orderly a manner as possible by windrowing or cutting trunks into manageable lengths (6 feet).

2.43 New right of way in a development to be served underground:

Developer shall be required to clear right of way including stumps for at least all primary cable routes and all conduit installations per section 2.0355.

2.44 Service laterals in a development to be served underground:

It will be the individual builder's responsibility to make a formal application for service to the Cooperative at the time that the meter can and all conduits have been installed. It will also be the responsibility of the home builder to furnish and install conduit with pull string, per Cooperative specifications, from the meter can to the lot corner. At the lot corner, the home builder must connect as well as furnish material for connecting to the Cooperative's conduit system. The installation and integrity of the conduit is the responsibility of the home builder until such time that the Cooperative has successfully installed cable in the conduit. Any work required, above normal construction practices, by the Cooperative will be at the expense of the home builder.

Once the Cooperative has successfully installed cable in the conduit, the conduit, along with any fittings, shall become the sole property of the Cooperative at no charge to the Cooperative.

SECTION 3

TYPE AND CHARACTERISTICS OF ELECTRIC SERVICE

3.01 Characteristics of Service

Electric service supplied by the Clay Electric Cooperative, Inc., is alternating current with a frequency of 60 Hertz.

3.02 Types of Electric Service

3.21 Voltage for Lighting - Overhead and Underground Distribution:

The nominal voltage at the point of delivery for typical lighting service is 120/240 Volts, 3-wire, single-phase.

3.22 Voltage for Lighting and Power

The following service voltages will be supplied for qualifying loads upon prior approval of the Cooperative:

1. 120/240 Volts nominal, 4-wire, 3-phase Delta
2. 120/208 Volts nominal, 4-wire, 3-phase Wye
3. 120/208 Volts nominal, 3-wire, single phase
4. 240/480 Volts nominal, 4-wire, 3-phase Delta
5. 277/480 Volts nominal, 4-wire, 3-phase Wye
6. 7200/12470 Volts nominal, 4-wire, 3-phase Wye
7. 14400/24900 Volts nominal, 4-wire, 3-phase Wye

3.23 The voltage and number of phases which will be supplied depend upon the character of the load, its size, and location. It is necessary that the member consult the Cooperative regarding type of service, which can be furnished before proceeding with the purchase of equipment or installation of wiring.

3.03 Service Voltage Limits

Insofar as possible, the Cooperative will design and operate its electric systems so that most service voltages are within a limit of 5% above or below the service voltage assigned. Service voltage shall be defined as the voltage at the point where the electric system of the Cooperative and the member are connected. This is usually considered the voltage at the meter socket or the service entrance point.

Upon request, the Cooperative will test the voltage supply to the member and take corrective action if it is found to be consistently outside the specified limits. The member shall be responsible for providing unusually close voltage regulation when required by the nature of the member's load.

3.04 Neutral Voltage

Small voltages may appear on the system neutral of the Cooperative's distribution system during the normal operation of the line. In most cases, this is not apparent to the member and causes no problems. A neutral voltage if present however, can on occasion cause problems on a dairy farm or other similar situation where animals being fed or worked with make contact with metallic objects and feel a small current caused by the voltage present.

If a member has reason to suspect that neutral voltage is causing problems with his farm operation, the Cooperative will assist the member in locating the source of the voltage. Because there are a number of possible causes for this type of problem, many of which are caused by faulty equipment owned by the member, a thorough investigation is required to isolate and correct the problem. It is recommended that the member contact a qualified electrician to inspect the wiring on his premises. (A check list is available as a guide - see Figure A.)

If, after investigation it is determined that the neutral on the Cooperative's system is contributing to the problem, the Cooperative will install a neutral isolator to separate the Cooperative's neutral from the member's grounding system. Because this is a nonstandard service which is not normally required and is not included in the standard rates charged, the member would be required to pay the cost of this installation.

SECTION 4

SECONDARY SERVICE - OVERHEAD

4.01 Member's Service Entrance

Beginning on 1/1/2018 and thereafter, new service wire from the point of take off to the meter location shall be underground unless otherwise approved by the Cooperative. Refer to Section 5 for Service-Underground requirements.

Service entrance wires between the Cooperative's service drop terminal and the member's service entrance should be as short as practical and enclosed in conduit. An approved type service entrance cable may be used where permitted by local code requirements, but not exposed to the exterior of the building.

The neutral conductor of each service entrance wiring shall be plainly marked at the service outlet and at the meter location.

The high leg of each 4 wire, 3 phase Delta service shall be plainly marked at the service outlet and at the metering point and preferably an orange marker should be used. The high leg shall be on the right hand side when facing meter base.

At least two feet of service entrance wire shall be left projecting from the service outlet fitting for connection to the service drop.

Where conduit is used, fittings with removable covers should be avoided in the service entrance run if possible. If such fittings cannot be avoided, they shall not be concealed.

Where a group of commercial occupancies are served from a service raceway, the covers to the pull boxes must be provided with means for sealing or locking where individual service taps are made to the raceway.

The location of the service entrance is important to both the member and the Cooperative. In order to avoid additional cost it is essential that the member contact the Cooperative as to where the service wires and meter should be attached to the building or other supporting structures.

The member's wiring shall be extended to the outside of the building wall to a point high enough to allow clearances as shown herein in Paragraph 4.03. An approved conduit extension shall be provided by the member if required to obtain specified clearances.

The member shall provide and install all material or equipment required for connecting the member's service equipment to the service drop or source of supply. The Cooperative will provide meter and meter base (meter base to be installed by the member.) There will be a contribution in aid to construction for every single phase meter base supplied by the Cooperative. This aid will be due and payable at the time the meter base is received.

4.02 Service Drops - Number per Building

No building shall be supplied from more than one service drop except by special permission of the Cooperative and as permitted by the National Electrical Code or by County Code.

4.03 Service Drops - Clearance

4.31 General

Clearances shall conform to the National Electrical Safety Code, American National Standards Institute C2.

4.32 Clearance Over Roofs

Service drops will not be installed over roofs. If the service drop exists, the service drop must meet clearance required of NESC over any newly installed roof.

Service drop conductors of 300 Volts or less to ground which do not pass over more than a maximum of 4 feet of the overhanging portion of the roof for the purpose of terminating at a service raceway mast, may be maintained at a minimum of 18 inches from any part of the roof over which they pass.

4.33 Clearance from Swimming Pools

Service drop conductors shall not be installed above a swimming pool, diving structure, observation stands, towers or platforms or surrounding area extending 10 feet horizontally from the pool edge. In no instance shall the clearance in any direction to the service drop from the pool surface, edge of water surface, or base of diving platform be less than 23 feet.

Clearance in any direction from the top of the diving platform or tower to the service conductor shall be more than 15 feet.

4.34 Minimum Vertical Clearance of Wires Above Ground:

	0-750 Volts To Ground	From 750 Volts to 15 kV To Ground
Roads, streets and other areas subject to truck traffic	16'	18.5'
Driveways, parking lots, and alleys	16'	18.5'
Spaces or ways accessible to pedestrians only	12'	14.5'

4.04 Service Drops - Anchorage

4.41 Location

The anchorage for the service drop shall be located on the building or structure at the nearest practical point to the pole and shall be mounted at such a height that the conductors will have the proper clearance as set out in Paragraph 4.034.

4.42 Construction

To fasten the service drop to the building, there are various types of cable grips and anchors used depending on the type of service drop conductors being used. These secure the cable to the building by use of an eye-bolt bolted through the wall or rafters. If the building is not high enough to get the proper service drop clearances above ground, a minimum, rigid 2 inch or larger steel conduit (steel tube or E.M.T. not acceptable) should be installed from the meter socket or enclosure up through the eaves for the dual purpose of supporting the service drop and enclosing the service entrance conductors. This type of installation is referred to as a mast.

The Cooperative will furnish an eye-bolt or an insulated conduit clevis for the member to install during construction.

4.43 Guying-Service Poles

As shown in Figures 1, 1A, and 4A, if the service drop is greater than 50 feet the member must guy their meter pole and install a guy marker on the guy.

4.05 Service Drops - Connectors

The service drop conductors will be connected to the service entrance conductors by means of wire or cable connectors. These connectors will be furnished and installed by the Cooperative.

4.06 Large Services

Because of mechanical support problems and the unsightly appearance of large overhead service conductors, large services may be run underground. The Cooperative reserves the right to make this determination.

4.07 Grounding

Grounding wires shall be installed in accordance with the requirements of the National Electrical Code and local authorities having jurisdiction.

Driven 5/8" ground rods or 3/4" galvanized pipe, both of a minimum length of 8 feet must be used for grounding. Water system grounding alone is not acceptable; however, the two may be tied together for more adequate protection.

SECTION 5

SERVICE - UNDERGROUND

5.01 Service Entrance Requirements

5.011 Location

The member shall contact the Cooperative to determine the required location of the service entrance.

5.012 Service Entrance Material and Installation

Underground service conductors will be installed from the Cooperative's point of take-off to the line side of the meter socket as specified herein under paragraphs for residential and commercial installations. Other material is specified in the following paragraphs as appropriate for residential or commercial.

5.02 Residential: Single Phase Underground

5.21 Underground Service off Overhead Line

Individual underground service off the overhead system will be installed in member furnished conduit for no charge. The installation and integrity of the conduit is the responsibility of the member until such time that the Cooperative has successfully installed cable in the conduit. Any work required, above normal construction practices, by the Cooperative will be at the expense of the member.

Once the Cooperative has successfully installed cable in the conduit, the conduit, along with any fittings, shall become the sole property of the Cooperative at no charge to the Cooperative. Member should refer to Figures in Appendix for proper burial depth and size of conduit.

5.22 Underground Primary Extensions

The Cooperative, when requested by an applicant, will provide single phase 120/240 Volt underground electric distribution facilities for residential and non-residential service as defined in paragraphs A, B, and C below at charges that reflect the annual average cost difference between overhead and underground.

The schedule of charges per meter is as follows:

- A. To single family unattached houses with a maximum average lot size of 1/2 acre and a minimum of twelve (12) units = \$800.00.
- B. To multifamily developments with one service installed to a ganged meter center with a density of six (6) units/acre, and with a minimum of twelve (12) units (If developer installs conduits per Clay specification per meter charge will be waived) = No Charge

- C. All other single-phase underground extension and all three phase underground extensions will be in conduit and charged in accordance with the following formula:

Underground Distribution Facilities-For Residential (R) services underground primary installations will be in conduit installed by the Cooperative at a cost in accordance to the below formula.

Residential

$$\begin{aligned}
 CIAC_{UG} = & \text{(Actual or estimated job cost)} &&) \\
 & \text{(for all material required to)} &&) \\
 & \text{(provide service excluding)} &&) \\
 & \text{(the service drop and meters)} &&) \\
 & &&) \\
 & - \text{(4X nonfuel energy charge per)} &&) \\
 & \text{(kWh X expected annual kWh)} &&) \\
 & \text{(sales over the new line)} &&) \\
 & &&)
 \end{aligned}$$

Non-Residential

$$\begin{aligned}
 CIAC_{UG} = & \text{(Actual or estimated job cost)} &&) \\
 & \text{(for all material required to)} &&) \\
 & \text{(provide service excluding)} &&) \\
 & \text{(the service drop and meters)} &&) \\
 & &&) \\
 & - \text{(4X nonfuel energy charge per)} &&) \\
 & \text{(kWh X expected annual kWh)} &&) \\
 & \text{(sales over the new line)} &&) \\
 & &&) \\
 & - \text{(4X expected annual demand)} &&) \\
 & \text{(charge revenues from sales)} &&) \\
 & \text{(over the new line)} &&)
 \end{aligned}$$

- D. The costs above are based on the Cooperative's being able to install conduit by standard open trenching practices. Should the Cooperative encounter obstacles such as rock subsoil that prevent standard trenching operations, additional aid-to-construction may be required. If this occurs, the Cooperative will require approval of Owner or Developer before proceeding.

5.23 Member Owned Underground Service

The Cooperative will connect a member owned underground service under the following conditions:

- A. Service is installed in accordance with all applicable codes.
- B. The meter shall be located ahead of the service. The location of the meter will identify ownership. The member shall own and maintain all facilities behind the meter.

5.03 Underground Service - Commercial

5.31 Underground Service (Rate classes GS, GSD, LGSD & LGSDT/LM)

The member shall install service conduit per Cooperative standards. Cooperative will install service wire free of charge.

5.32 Availability

Single phase underground service will be extended from either a pole or padmount transformer as is most practical at a voltage of 120/240. The 240/480 volt application may be available upon request.

Three phase underground service will be extended from either a pole or padmount transformer as is most practical. Only the following voltages are available when a padmount transformer is used:

120/240 Delta	25 kVA through 75 kVA
120/208 GRDY	75 kVA through 1000 kVA
277/480 GRDY	75 kVA and larger

5.33 The Cooperative will provide and install the following equipment:

- A. Transformer as required
- B. All conductor and connections on the line side of the meter when metering is self contained. This includes connections at transformer if conductor supplied by Cooperative.
- C. Current transformers, wiring and meter socket when installed on the transformer. This will only be used when one service is extended from the transformer (Figure 18).
- D. Meter
- E. Cooperative will install member furnished conduit sweeps (PVC or Metal) if they terminate in an energized transformer or enclosure. Member is to coordinate this installation with Cooperative.
- F. Cooperative will connect all conductors, even member furnished, at the transformer if transformer is energized.

5.34 The Cooperative will provide for the member to install the following:

- A. A three phase meter socket (standard type only) will be furnished by Clay Electric when installed on the member's building. For any single-phase meter sockets furnished there will be an aid to construction cost payable to the Cooperative at the time of receipt of meter socket.

5.35 The member will provide and install the following equipment:

- A. Transformer pad if required
- B. Two parallel conduit runs with pull strings for primary conductor. These shall include sweeps of at least 24" radius to turn up the pole or into a URD enclosure. If the member furnished sweeps turn up into an energized URD enclosure the Cooperative will install. The member is to coordinate this installation with Cooperative. **AT NO TIME IS THE MEMBER OR THEIR ELECTRICIAN TO WORK INSIDE THE COOPERATIVE'S ENERGIZED EQUIPMENT.** The installation and integrity of the conduit is the responsibility of the member until such time that the Cooperative has successfully installed cable in the conduit. Any work required, above normal construction practices, by the Cooperative will be at the expense of the member. Once the Cooperative has successfully installed cable in the conduit, the conduit, along with any fittings, shall become the sole property of the Cooperative at no charge to the Cooperative.
- C. Conduits and pull strings as required for service conductors. This shall include ells to turn up the pole or into a URD transformer. If the member furnished ells turn up into an energized URD transformer the Cooperative will install. The member is to coordinate this installation with Cooperative. **AT NO TIME IS THE MEMBER OR THEIR ELECTRICIAN TO WORK INSIDE THE COOPERATIVE'S ENERGIZED EQUIPMENT.** The installation and integrity of the conduit is the responsibility of the member until such time that the Cooperative has successfully installed cable in the conduit. Any work required, above normal construction practices, by the Cooperative will be at the expense of the member. Once the Cooperative has successfully installed cable in the conduit, the conduit, along with any fittings, shall become the sole property of the Cooperative at no charge to the Cooperative.
- D. All conductor and connections on the load side of the meter. This includes service conductors if service is CT metered at the transformer. If transformer is energized the member must coordinate conductor installation and connection with Cooperative. The Cooperative will perform any work required during installation and connection at the transformer if transformer is energized. **AT NO TIME IS THE MEMBER OR THEIR ELECTRICIAN TO WORK INSIDE THE COOPERATIVE'S ENERGIZED TRANSFORMER.** The Cooperative will furnish its standard connectors for the secondary of the transformer.
- E. Enclosure for current transformers, if required, when CT metered at

the member's building. This shall be required for CT metering when more than one service is extended from the transformer providing service. Conduit and pull string shall be provided from enclosure to meter socket. An approved means of disconnect shall be provided to separate the Cooperative's service conductors from the member's service entrance conductors and shall be located outside adjacent to the CT enclosure. Enclosure, meter socket and disconnect shall be located as approved by the Cooperative on the outside of the building (Figure 17).

- F. Any special meter socket which is not furnished by the Cooperative shall require prior approval of the Cooperative.

SECTION 6

METER INSTALLATIONS

6.01 Meter Location

The location of meters is an important consideration to both the Cooperative and the member. The Cooperative should always be consulted and will endeavor to select a location that will be the most suitable to both parties. Normally all metering will be outdoors.

In the event that a meter area is later enclosed, the member shall, at his expense, have the meter facilities moved to an outside location.

Meters for apartment houses, offices, or commercial buildings should, where possible, shall be outside but they may be grouped together in a meter room provided for that purpose. Meters installed outdoors should be located on the building in a place where they will be protected from mechanical injury.

Meter sockets and enclosures shall be securely mounted in a plumb and level position on a solid wall or structure. When mounted on masonry walls or structures, meter sockets and enclosures shall be secured with screws set in lead shields or with toggle bolts. Wood pegs shall not be used. The center of the meter shall not be more than 6 feet from the ground or less than 4 feet.

Meters shall be located outside on the first floor and shall be easily accessible at all times for reading and testing. Meters shall not be installed near belts or other moving machinery endangering the safety of those doing work about the meter.

The member shall furnish and install meter boards, service switches, and other equipment to form a complete wiring system. Mounting devices that are not provided with hangers for the meter equipment shall have boards installed in back of them to permit the meter equipment to be attached with wood screws. These boards shall be of a clear, soft, dressed wood at least 3/4 inch thick, free from knots and cracks and painted with a good quality paint. They shall be securely fastened to the wall in a vertical position.

A clear space of at least 60 inches shall be maintained in front of all meters for reading and testing and the Cooperative shall have the right of entry to the member's premises at reasonable hours to install, read, inspect, repair or remove meters or other system-owned equipment used to supply electricity.

6.02 Identification of Meters

All meter sockets or enclosures on multiple occupancy dwellings, mobile home parks, or commercial services requiring the use of more than one meter at a location shall be permanently identified as to street number, apartment number, building section or other permanent location designation which that meter serves.

6.03 Single Phase Meter Installations

The member may obtain a meter socket from the Cooperative or purchase a Cooperative approved meter socket from a local supplier. The metering sockets forming portions of the wiring installations shall be installed by the member as a part of his wiring. All meter sockets once installed become the property of the Cooperative. For all single-phase meter sockets furnished by the Cooperative there will be an aid to construction cost payable at the time of receipt of meter socket.

6.31 150 Amperes or Less

On installations where the service entrance conductors are sized for 150 amperes or less, a meter socket with a 2 inch hub can be reduced down to accommodate smaller conduits as required.

6.32 200 Amperes or Less, but More than 150

On installations requiring service entrance conductors to carry up to 200 amperes, the Cooperative will furnish a 200 ampere rated socket with a 2-inch hub as required. There will be an aid to construction cost for all single-phase meter sockets.

6.33 Over 400 Amperes

Installations of this size will necessitate the use of instrument current transformers. The Cooperative shall be consulted on all installations of this character before any work is done.

6.04 Four-Wire, Three-Phase Meter Installations

6.41 400 Amperes or Less

On installations of 400 amperes or less, the Cooperative will furnish a suitable socket type meter base.

6.42 Over 400 Amperes

On installations over 400 amperes the use of instrument current transformers will be necessary. The Cooperative shall be consulted on all installations of this character before any work is done.

6.43 Main Disconnect Rule

There shall be a Main Disconnect on the source side of any self-contained meter 480V Phase to Phase. The disconnect has to be labelled "Source side disconnect".

6.05 Instrument Transformer Installations

On installations requiring the use of instrument current transformers, the member will furnish a Cooperative approved enclosure.

All wiring except that from the secondary terminals of the current transformers to the meter shall be completed by the member: Along with this the member will furnish and install all conduit and pull wire required for meter installation.

6.06 Impulse Metering for Large Services

Certain large use members may wish to investigate the incorporation of impulse equipment within the meter for the explicit purpose of load monitoring and control. The Cooperative makes this convenience available and will install the necessary equipment at their metering station. The cost of such equipment and labor shall be borne by the member and only kilowatt impulse equipment will be provided. The member will have the responsibility for all other wiring beyond the metering point.

6.07 Time-of-Use Metering

Certain members, if eligible, may choose one of the Cooperative's time-of-use rates. The Cooperative makes these rates available and will install the necessary equipment at the metering station. The cost of this equipment installation will be borne by the Cooperative. The member will have the responsibility for providing a standard telephone line to the metering station. This phone line should be a private line and if member is using PBX equipment, the metering station should be installed preferably on a telephone line, which does not go through PBX. The Cooperative shall be consulted on all installations of this character.

SECTION 7

PRIMARY SERVICE

7.01 General

Primary metered service is available to members who provide, install and maintain their own distribution system and equipment unless otherwise specified in the contract for service. The metering of this service will be at the primary voltage level at a voltage determined by the Cooperative. Normally primary service will be made available only to members with a minimum demand of 300 kVA.

7.02 Metering

7.21 Location

The member's service location for primary service is at the metering point and to be placed within access of the Cooperative. Beyond the metering is fully the member's responsibility unless otherwise specified in the contract for service. The Cooperative shall approve location.

7.22 Metering in Member's Substation

At a member's request, metering will be incorporated within the member's substation or switchgear. Contact should be made as early as possible to allow for coordination of the proposed installation.

7.23 Protective Equipment

Protective equipment as required on the load side of a meter installation shall be provided by the member as directed and approved by the Cooperative.

7.03 Cooperative owned equipment behind Primary Meter

The Cooperative will furnish service under the GSD, GSDD/LM, LGSD, LGSDT/LM, HLF, SS, INT, INT-T, AND INT-C at a single voltage. Equipment to supply additional voltages or additional facilities for the use of the member shall be furnished and maintained by the member. The member may request the Cooperative to furnish the additional equipment and facilities, and the Cooperative at its sole option, may furnish install, operate and maintain such additional equipment and facilities, charging the member for the use thereof at the rate of 1.75% per month of the installed cost of such additional equipment and facilities.

SECTION 8

MEMBER UTILIZATION EQUIPMENT

8.01 General

The Cooperative builds and maintains adequate lines to supply proper service to all members using normal equipment. However, since equipment installed by one member may affect the adequate service to other members and because the misuse of some equipment would constitute a life or fire hazard, the Cooperative has prepared the following regulations covering the more common installation of utilized equipment.

The Cooperative specifies only such requirements as are necessary to safeguard both its members and the Cooperative to the end that service may be rendered with a maximum of safety and with a minimum of interruption or disturbance. The member shall consult the Cooperative for details on special equipment.

8.02 Motors

In order to insure a good quality of service, the Cooperative has established certain limits for the maximum allowable starting currents of motors to be connected to their lines. Single phase motors not exceeding 5 horsepower and three phase motors not exceeding 20 horsepower may be installed without restrictions.

8.021 Motors - Starting Methods

Motors larger than specified above shall require completion of a Motor Start Application, Exhibit A. These are available from the Cooperative. In the event that starting equipment is required, the maximum starting current will be specified and equipment shall be installed by the member prior to the service being connected. The number and frequency of starts may also be specified by the Cooperative.

8.022 Voltage Fluctuation Due to an Existing Motor

The Cooperative shall require the member to correct voltage fluctuation exceeding 2% when affecting another member.

8.03 Special Equipment

8.31 Non-Standard Equipment

The member is cautioned against the purchase and use of any type of electrical equipment that is NOT OF STANDARD MANUFACTURE AND IS NOT APPROVED BY A COMPETENT AUTHORITY (such as Underwriter's Laboratories).

8.32 Flashing Signs

All flashing signs or lights served by the Cooperative shall be provided with the necessary type of switching equipment to eliminate undesirable flicker and radio trouble interference to other members.

8.33 Other Equipment

Due to the very severe operating characteristics of such equipment as electric welders (particularly of the transformer type), strip heat, furnaces, x-ray, wireless and radio broadcasting stations, the member shall apply to the Cooperative for approval to use such equipment before installation is made. When the operation of any equipment is detrimental to satisfactory operation of the Cooperative's distribution system, the Cooperative may require the installation of special protective equipment at the expense of the member.

8.04 Member Owned Generators

If a member purchases a portable generator, the Cooperative recommends this unit not be wired into a home's distribution panel or into a receptacle that is connected to a home's electrical system. Appliances should be plugged directly into the generator or plugged into a heavy-duty extension cord, which is plugged directly into the generator.

If a member wishes to permanently install an emergency or standby generation system, a switching and control scheme or a mechanically interlocked transfer switch shall be provided by the member to preclude the possibility that any energy generated by the member's equipment will back feed into the Cooperative's system (reference Figure 22). The member should check with the local county authorities to determine if any permits or inspections are required. Such generation systems and their associated equipment shall be installed by a Licensed Electrician. Failure to provide such safety switching equipment shall subject the member to possible disconnection of electric service by the Cooperative.

8.041 Meter Base Transfer Switch

There are now available several manufacturers of transfer switches that can be installed between the meter and meter base. The Cooperative does not object to the installation of these type transfer switches.

- A. The member must use a Cooperative approved meter base transfer switch. At present the only switches approved are:
 1. GenerLink
Global Power Products
1-800-886-3837

2. GenConnect
Models: LG-050M210
LG-050M213
Electro Industries, Inc.
1-800-922-4138

If member desires to use another brand, they must first receive approval from Cooperative. Failure to receive prior approval could subject member to possible removal of switch from meter base by Cooperative.

- B. The meter base the transfer switch is to be mounted in must be rated at 200 amperes and constructed of rigid metal (not aluminum) and firmly attached to the wall or pole.
- C. The transfer switch must be installed by a licensed electrician. The electrician must call the Cooperative notifying us he is cutting the meter seal to install the transfer switch. The electrician must install the transfer switch and meter according to manufacturer's specifications. If a new or additional meter band is needed the electrician can get one at no charge from a local Cooperative office.
- D. A Cooperative representative will reseal the meter base and inspect the installation when in the area or during the next meter reading cycle. Should the inspection reveal an improper installation the Cooperative may remove the improper transfer switch.

8.05 Harmonics

The Cooperative shall require the member to correct voltage distortion when such distortion due to harmonic loads of the member equals or exceeds 5% THD of the delivery voltage.

8.06 Interconnection Guidelines of Member-Owned Distributed Generation

8.61 The Cooperative entered into a Wholesale Power Contract (WPC) with Seminole Electric Cooperative, Inc. ("Seminole"), effective as of July 30, 1975, which, as amended, has a term through December 31, 2055. The WPC provides among other things that the Cooperative shall purchase from Seminole all electric power and energy which the Cooperative shall require for the operation of the Cooperative's system.

8.62 In 1978 Congress enacted the Public Utility Regulatory Policies Act of 1978 ("PURPA"). The Federal Energy Regulatory Commission ("FERC") adopted rules implementing PURPA, particularly, sections 201 and 210 that require the Cooperative and Seminole to interconnect with and to buy from and to sell to Qualifying Facilities ("QF") as defined by PURPA. As a result, the Cooperative and Seminole received permission from FERC to operate as a single entity for purposes of implementing PURPA. It is the policy of the Cooperative and

Seminole: (1) to permit any QF to interconnect with Seminole's transmission system, or the distribution or transmission system of the Cooperative; (2) to permit any QF to sell energy and capacity to Seminole; (3) to permit any QF to purchase supplementary, back-up, maintenance, and interruptible power from the Cooperative at rates that are nondiscriminatory, just and reasonable, and in the public interest; and (4) to permit any QF so requesting to wheel its energy and capacity over the distribution or transmission system of the Cooperative and/or the transmission system of Seminole, to the extent transmission or distribution capacity is available, to any electric utility purchasing such power. Seminole develops, amends, and maintains the interconnection guidelines, standard offer contracts, and applicable rate schedules. Upon a member's request, the Cooperative will furnish these documents.

- 8.63 Effective January 1, 2009 the Cooperative and Seminole amended the WPC to allow the Cooperative to net meter renewable energy resources located on member's premises. The terms of net metering are described in the Cooperative's rate tariffs along with an interconnection agreement. These rates and agreements may be viewed and downloaded on the Cooperative's website www.clayelectric.com.
- 8.64 All other distributed generation installations not meeting paragraphs 8.062 and 8.063 and desiring to operate in parallel with the Cooperative's electrical system shall first contact the Cooperative and provide detailed equipment specifications. It is the Cooperative's policy that any such interconnection should follow the Institute of Electrical and Electronics Engineers ("IEEE") standard 1547 for Interconnecting Distributed Resources with Electric Power Systems as they may be amended from time to time. The member must certify in writing that the proposed installation meets IEEE Standard 1547.

The Cooperative after review of member's interconnection request may deny request or if approved Cooperative will prepare specific interconnection agreement for this installation. The member must execute an interconnection agreement before interconnecting.

SECTION 9

MAINTENANCE OF SERVICE

9.01 Alterations and Additions

9.011 Increase in Service Size

Connection to the member's premises is made with service wires, meters, transformers, and other necessary facilities to properly supply adequate electric service for the operation of the member's installation in accordance with the application. If any additional load of substantial size is added, the Cooperative shall be notified so that satisfactory service may be maintained.

To safeguard both the property of the member and that of the Cooperative, the member must not overload or overfuse any service or branch circuit.

9.012 Relocation of Cooperative's Facilities

A member may request the Cooperative to relocate or rearrange its facilities to better accommodate the member. If, in the opinion of the Cooperative, such relocation is for the sole benefit of the member or is necessary because of changes on the member's premises to allow the Cooperative to maintain compliance with the National Electrical Safety Code and Section 9.04 of this Standard, and without the Cooperative receiving any benefits due to the relocation, the member will be charged the cost of the relocation.

If, in the opinion of the Cooperative, there is a mutual benefit for the member and the Cooperative for the Cooperative to relocate, the relocation will be performed by the Cooperative at no cost to the member.

9.02 Protection by Member of Cooperative's Property

The member shall properly protect the Cooperative's property on a member's premises and shall permit no one but persons authorized by law to have access to Cooperative owned wiring, meters, and apparatus. In the event of any loss or damage to the property of the Cooperative caused by or arising out of carelessness, neglect, misuse by the member the cost of replacing or repairing such damage shall be paid by the member. The member shall not plant any vegetation that would interfere with the Cooperative's adjacent overhead conductors, hinder ventilation for and maintenance of any padmounted facilities or obstruct visual reading of electric meters.

9.03 Right of Entry

The Cooperative shall have the rights of entry to the member's premises at reasonable hours to install, read, inspect, repair or remove meters or other system-owned equipment used to supply electricity.

9.04 Easement Restrictions

The Cooperative restricts the use of the easement to general farming, citrus groves, or pasture purposes, as long as such does not interfere with the Cooperative's use of the easement. The easement is to be clear of all buildings, structures or other obstructions except citrus trees, low-growing shrubbery and fences that do not otherwise interfere with Cooperative's use of the easement. The Cooperative specifically prohibits the construction of any aircraft runways or taxiways, both private and public, on Cooperative's easements.

SECTION 10

OUTDOOR LIGHTING SERVICE

10.01 General

The terms and conditions contained in this General Section 10.01 apply to all services provided in this Section 10.

Cooperative will provide public roadway lighting and area lighting services in accordance with Rate Schedules RSL, L, and FL and Cooperative policy. The lighting design will consist of suitable lighting patterns for roadway and area lighting projects using our standard fixtures and taking in account the member's request.

The Cooperative, while exercising reasonable diligence to furnish outdoor lighting services, does not guarantee continuous service, regardless of the type of service provided, and will not be liable for damages for any interruption, deficiency or failure of service, and reserves the right to interrupt service at any time necessary for repairs to lines or equipment. The member shall be solely responsible for notifying the Cooperative of any required repair and replacement services to the facilities, and such services will be provided during regular daytime working hours, Monday through Friday, as soon as practicable after verification and subject to appropriate operating policies and procedures, the availability of replacement parts and other matters beyond the control of the Cooperative. **The Cooperative specifically does not warrant or guarantee that the outdoor lighting services shall meet any lighting standard, including, but not limited to, the location of the facilities and the illumination provided.**

Member waives any claim, liability, damage (both as to persons and property, including death), costs, expenses, and attorney's fees (collectively referred to for purposes of this paragraph as "claims") that the member may have or assert against the Cooperative arising out of the service provided hereunder, or the failure, interruption, inadequacy or insufficiency of the service provided. Member shall defend, indemnify, and hold harmless the Cooperative from all claims asserted against the Cooperative arising out of the services provided hereunder, or the failure, interruption, or insufficiency of the service provided. Outdoor lighting services shall not include maintenance, monitoring, or inspection.

The Cooperative is not responsible for trimming trees that may either obstruct light output from fixture or that obstruct repair or replacement access to the light fixture. The member will be responsible for trimming trees around lights. Due to the possibility of high voltage, lines near the light the member should contact the Cooperative before trimming any trees around the light so the Cooperative can

determine if it will be safe for the member to trim the trees.

The Cooperative may remove any outdoor light fixtures and/or poles that require repeated repairs due to vandalism. The Cooperative will notify the member or agency of its intent to remove the lighting equipment. The member or agency will have the option of continuing service if it agrees to pay all excess repair expenses resulting from vandalism as determined by Cooperative.

10.02 Public Roadway Lighting

Cooperative will install lighting on any public roadway upon written request and approval from the city, county, state, or other governmental agency having jurisdiction. All such lighting will be covered by a contract executed by Cooperative and the authorizing government agency.

The amount of illumination required in a roadway lighting system varies based on roadway classification, pavement type, and presence of pedestrian sidewalks.

The Cooperative will exercise reasonable diligence in designing and installing roadway lighting that meets member needs as well as conforming to applicable standards such as American Association of State Highway and Transportation Officials Street lighting Guidelines (AASHTO Guidelines) or Illuminating Engineering Society (IES) standards.

The Cooperative does not guarantee these lighting levels throughout the life of the installation and will not be liable for damages for any obstructions or deterioration that would reduce the fixture output at roadway level. The member or agency responsible for roadway shall be responsible for maintenance of right-of-way to trim or remove any trees or obstacles that would reduce the fixture output at roadway level.

The Cooperative's standard installation includes mounting light fixture on an existing pole. A monthly fee as defined in rate schedules L and FL will be added if a new pole must be added to install the light. Where more than a standard wood pole and service drop is required, the member will be charged for the additional cost. If a transformer must be installed for the exclusive purpose of providing service to the light, the member shall be charged the materials, labor, and overhead costs for the transformer.

For Cooperative owned and installed street lighting facilities, a contribution in aid of construction (CIAC) will be required from the member for:

1. The installation cost of any new overhead distribution facilities for the exclusive purpose of providing service to the lights, exclusive of the installed cost of a standard lighting fixture itself and one span of

service wire to the light.

2. The installation cost of any new underground distribution facilities for the exclusive purpose of providing service to the lights, exclusive of the installed cost of a standard lighting fixture itself and the equivalent cost of one span of overhead service wire to the light.

This CIAC if any shall be paid by Member before the commencement of any construction work by the Cooperative.

The only exception to the above design standards will be systems designed for subdivision roadways. These type roadways often contain many curves and cul-de-sacs, which make uniform lighting difficult. These will comply with the standards described in Section 10.021.

Once installed the roadway lighting will be repaired or replaced by the Cooperative. The member or governmental agency requesting the lighting shall be solely responsible for notifying the Cooperative of any lights needing repair or replacement services. These services will be provided during regular daytime working hours, Monday through Friday, as soon as practicable after verification (Cooperative goal is 3 working days) and subject to appropriate operating policies and procedures, the availability of replacement parts and other matters beyond the control of the Cooperative. These services are subject to any specific contract the Cooperative may have executed with a member or governmental agency.

10.21 Subdivision Roadway Design Standard

Standard lighting practice along subdivision roadways will not adhere to AASHTO or IES guidelines due to the many varied roadway curves, cul-de-sacs and homes with close proximity to roadway.

The Cooperative's standard design on these roadways will consist of standard lighting fixtures at potential areas of conflict such as intersections, curves and cul-de-sacs. Standard light fixtures will then be installed between these conflict areas to "fill in" the roadway lighting. This typically consists of lights installed every 200 – 300 feet.

This standard does not apply to any main boulevard or collector roadway within a subdivision. Their lighting standard will be as described in 10.02 above.

This design will be done before determining which charge to use under the Cooperative's RSL rate schedule.

Should additional poles need to be added in subdivisions served by overhead distribution lines, the Cooperative shall charge the developer as applicable in the rate schedules of the Cooperative to cover the cost of the additional poles. If a transformer must be installed for the exclusive purpose of providing service to the light, the member shall be charged the total cost of the installed transformer. Where the subdivision is served by underground distribution lines, the Cooperative will furnish and install its standard lights provided the applicant for such service pays for the installed cost of such lighting system.

10.22 Public Roadway Intersection Lighting

Cooperative will install lighting at any public road intersection upon written request from member and approval from the city, county, state, or other agency having jurisdiction over the public roadway. All such lighting will be covered by a contract executed by Cooperative, member and agency responsible for roadway.

Intersection shall be defined as joining of two public roadways or a private/public driveway onto a public roadway.

The Cooperative will exercise reasonable diligence in designing and installing roadway lighting that meets member needs as well as conforming to applicable standards such as AASHTO Guidelines or IES Standards.

Typical installations are shown in Figures 23-25. If intersection needing lighting is not shown in Figures 23-25, the Cooperative will provide a design specific to members' intersection.

All other conditions of section 10.02 Public Roadway Lighting shall apply.

10.23 Crosswalk/Bus Stop Lighting

The Cooperative will install lighting for these areas under the same conditions as Public Roadway Intersection Lighting Section 10.022.

Typical installations are shown in Figure 26. If crosswalk or bus stop needing lighting is not shown in figure 26, the Cooperative will provide a design specific to members' request.

10.03 Residential Outdoor Lighting

The Cooperative will furnish and install any of its standard outdoor lights for a residential member provided such residential member agrees to pay a charge as applicable in the Cooperative's rate schedules L and FL.

This outdoor lighting is for year-round outdoor lighting of yards, walkways, or other areas on property owned by the requesting residential member.

The light must be faced towards private property if installed on poles along an adjacent roadway.

The Cooperative does not design to or guarantee minimum outdoor lighting levels based on any IES standards. These lights are located solely on direction and request of residential member for their use and pleasure.

The Cooperative will not be required to install outdoor lighting at any location where the service may be objectionable to others. If it is determined after installation that the light is objectionable, the Cooperative may terminate the service without obligation or liability.

The Cooperative's standard installation includes mounting light fixture on an existing pole. A monthly fee as defined in rate schedules L and FL will be added if a new pole must be added to install the light. Where more than a standard wood pole and service drop is required, the member will be charged for the additional cost. If a transformer must be installed for the exclusive purpose of providing service to the light, the member shall be charged the materials, labor, and overhead costs for the transformer.

The member shall be solely responsible for notifying the Cooperative that a light is not working properly or is out. The Cooperative will repair or replace the light during regular daytime working hours, Monday through Friday, as soon as practicable after verification (Cooperative goal is 7-10 working days) and subject to appropriate operating policies and procedures, the availability of replacement parts and other matters beyond the control of the Cooperative.

10.04 Public/Commercial Outdoor Lighting

The Cooperative will furnish and install any of its standard outdoor lights for a commercial member or public agency in accordance with Rate Schedules L and FL and Cooperative policy. All such lighting will be covered by a contract executed by Cooperative and the commercial member or public agency.

This outdoor lighting is for year-round outdoor lighting of parking areas, storage area, boat ramps, parks, or other areas on property owned by the requesting party. **The light must be faced towards private property if installed on poles along an adjacent roadway.**

Unless required by executed contract the Cooperative does not design to or guarantee minimum outdoor lighting levels based on any IES standards. These lights are located solely on direction and request of member or public agency for

their use and pleasure.

The Cooperative will not be required to install outdoor lighting of any location where the service may be objectionable to others. If it is determined after installation that the light is objectionable, the Cooperative may terminate the service without obligation or liability.

The Cooperative's standard installation includes mounting light fixture on an existing pole. A monthly fee as defined in rate schedules L and FL will be added if a new pole must be added to install the light. Where more than a pole, light fixture and service drop is required, the member will be charged for the additional cost. If a transformer must be installed for the exclusive purpose of providing service to the light, the member shall be charged the materials, labor, and overhead costs for the transformer.

Member waives any claim, liability, damage (both as to persons and property, including death), costs, expenses, and attorney's fees (collectively referred to for purposes of this paragraph as "claims") that the member may have or assert against the Cooperative arising out of the service provided hereunder, or the failure, interruption, inadequacy or insufficiency of the service provided. Member shall defend, indemnify, and hold harmless the Cooperative from all claims asserted against the Cooperative arising out of the services provided hereunder, or the failure, interruption, or insufficiency of the service provided. Outdoor lighting services shall not include maintenance, monitoring, or inspection.

The member shall be solely responsible for notifying the Cooperative that a light is not working properly or is out. The Cooperative will repair or replace the light during regular daytime working hours, Monday through Friday, as soon as practicable after verification (Cooperative goal is 7-10 working days) and subject to appropriate operating policies and procedures, the availability of replacement parts and other matters beyond the control of the Cooperative.

**NEUTRAL VOLTAGE
CHECKLIST**

Yes*

No

Service Entrance Farm - Power Pole

- Connection to the Ground Rod - Loose, Corroded.....
- Covers loose.....
- Excessive rust

Barn Service Entrance

- Ground Rod missing at the service entrance.....
- Connection to Ground Rod - Loose, Corroded.....
- Covers loose.....
- Excessive rust.....
- Wet or Damp areas.....
- Large accumulation of feed dust on service box.....
- Frequent fuse blowing

Milk house

- Excessive rust on electrical boxes or conduit.....
- Water sitting on or in electrical boxes.....
- Covers missing or open to electrical boxes.....
- Wires sitting in water

In the Parlor or Around-The-Barn

- Pulsator wiring- Pinched Wires.....
 - Loose, Hanging wires.....
 - Scrapes, Breaks, or Cracks in insulation.....
 - Exposing the conductors.....
 - Broken Stall Cocks.....
- Excessive rust on electrical boxes or conduit.....
- Wires laying in wet or damp areas.....
- Electrical Boxes missing covers.....
- Loose, Hanging wires.....
- Broken or bend conduit.....

A General Review of all Farm Electrical Equipment

- Lights dimming when motors start.....
- Electrical shocks from any equipment.....
- Excessive rust on electrical boxes or conduit.....
- Wires, Electrical boxes, or Motors in wet or damp areas.....
- Accumulation of dust on or around electrical equipment.....
- Bent or Broken Conduit.....
- Scraped wire insulation exposing conductors.....
- Connections to service entrance Ground Rods - Loose, Corroded.....
- Extension Cords.....
- Electrical Boxes missing covers.....
- Loose, Hanging wires.....
- Motors operating irregularly under load, sparking, etc.....
- Electrical outlet missing third hole for ground.....

*A "**Yes**" Check-mark in this space indicates a potential problem. In most instances, a qualified electrician should be contacted for repair or replacement of the electrical equipment.

Figure A Sept. 29, 2020

Motor Starting Application

The following information to be completed by the member

Applicant Name: _____ Date: _____

Application of Motor: _____
Irrigation Pump, Air Compressor, Elevator, etc.

Starts Per Day: _____ Interval Between Starts: _____

Motor Phasing: Single Phase Three Phase

Motor Classification: Induction Synchronous

Motor Type: _____
Squirrel Cage, Wound Rotor, Shaded Pole, etc.

Motor Horsepower: _____ NEMA Code: _____ Motor Voltage: _____

Motor Starting Assistance: _____
Reduced Voltage Start, Resistive Start, Auto Transformer Start, etc. If none please specify.

If the motor will have starting assistance, explain the value. For example, if it is a reduced voltage start, give the amount of voltage reduction.

Will there be other motors starting simultaneously? Yes No

If "Yes", explain:

Additional Information:

Signature of Member *Date*

The following information to be completed by District Engineering

Substation Name: _____ Feeder Number: _____

Map ID: _____ Is the member/location: New? Existing?

Transformer Bank Type: _____ Total Transformer kVA: _____

Secondary Service Length: _____ Secondary Conductor: _____

The following information to be completed by Engineering Services

Request Status: Accepted Declined

Comments:

FIGURE B

Note: This form is needed for all three phase motors 20 hp and greater and for all single phase motors 5 hp and greater.

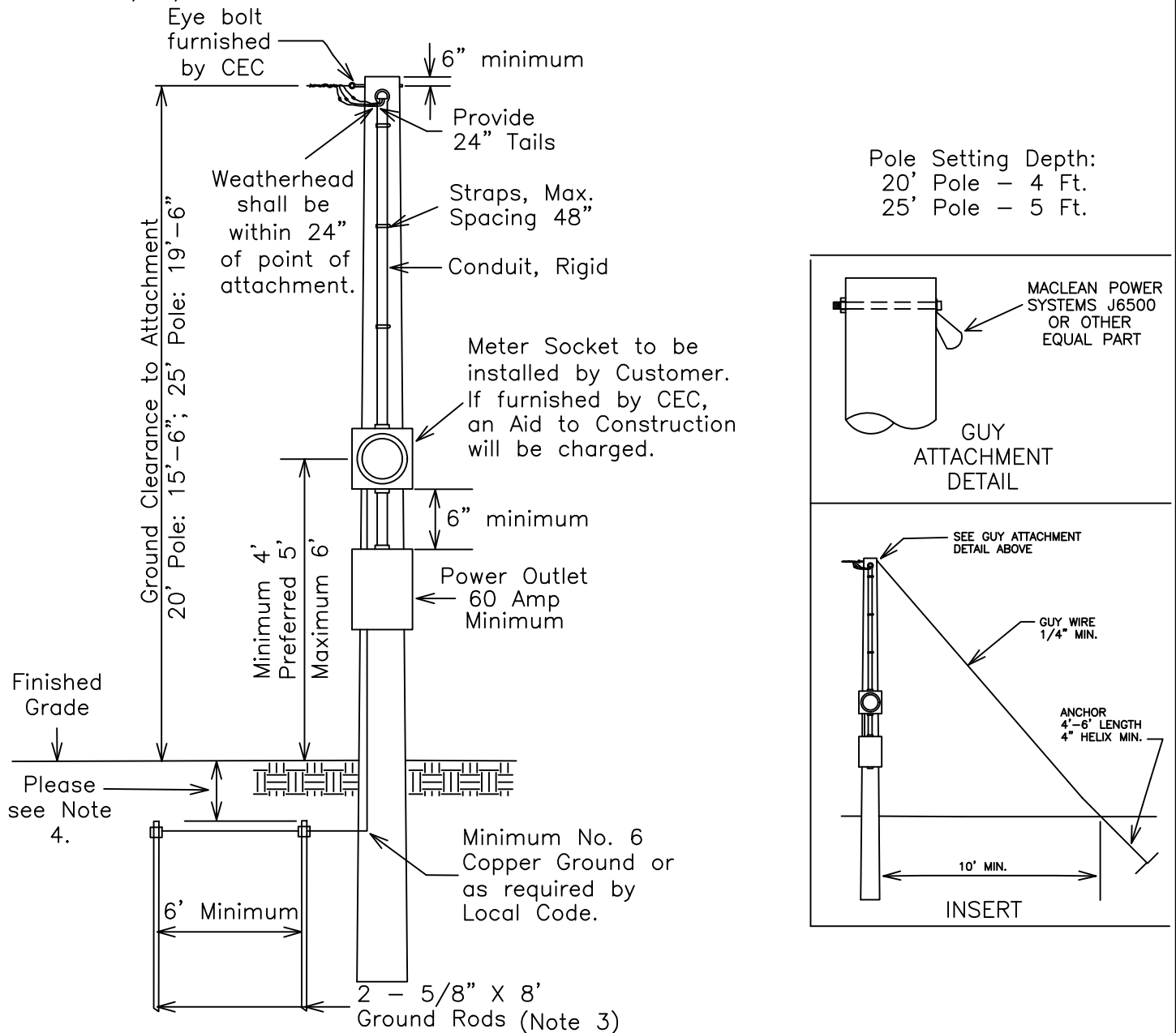

- Notes:
1. Pole shall be approved pressure treated with a minimum top circumference of 15" and a minimum length of 20 feet or as required to obtain required ground clearance. Consult CEC District Engineering for pole length requirement. Minimum Ground Clearance of service wire, including drip loop, over all driveways and other areas traversed by vehicles: 16' -0". Minimum Ground Clearance of service wire, including drip loop, over areas for pedestrians only: 12'-0".
 2. If service length is 50 feet or greater, guying is required. Refer to Insert detail.
 3. One 5/8" x 8' ground rod may be used if the measured resistance to ground is 25 ohms or less.
 4. The upper end of the grounding rod shall be flush with or below finished grade unless the above ground end and the grounding rod conductor attachment are protected against physical damage per NEC
 - 4.1. Member Shall adhere to county code requirements in conjunction with the NEC.
 5. Local codes that may exceed these requirements shall apply.
 6. Satellite dishes, area lights and other member owned attachments shall be a minimum of 12" below the service drip loop. Clearance shall be measured to the highest point of attached object. The most current National Electrical Safety Code (NESC) requirements shall apply.

01/01/13	Rev. 09/20/20	Esf1g1 2020.dwg
TYPICAL OVERHEAD TEMPORARY SERVICE		
FIGURE 1	CLAY ELECTRIC COOPERATIVE, INC. KEYSTONE HEIGHTS, FLORIDA	STANDARDS FOR ELECTRIC SERVICE

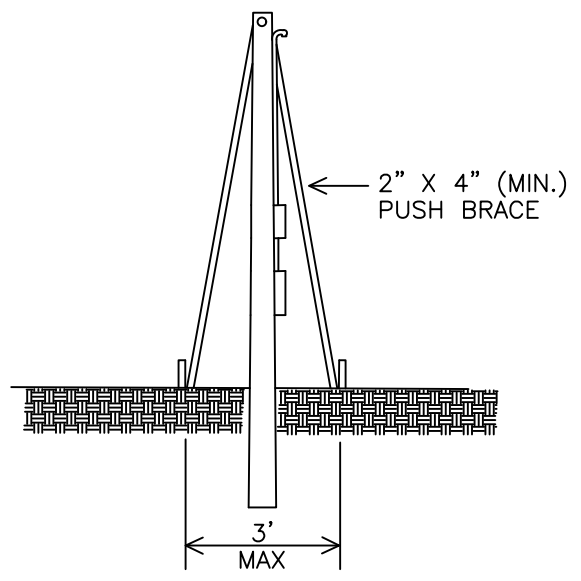
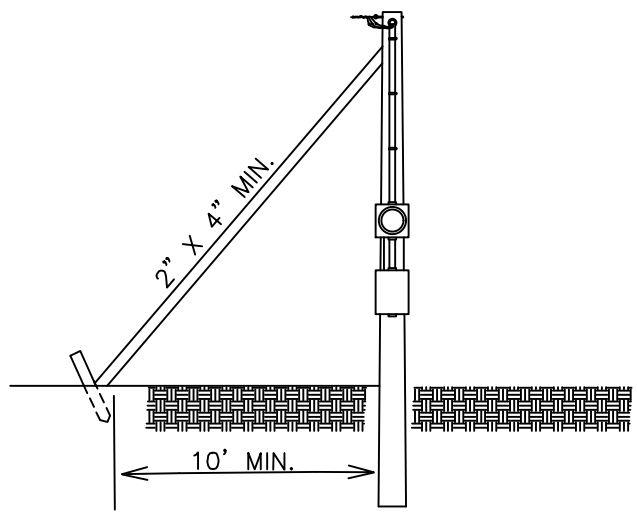
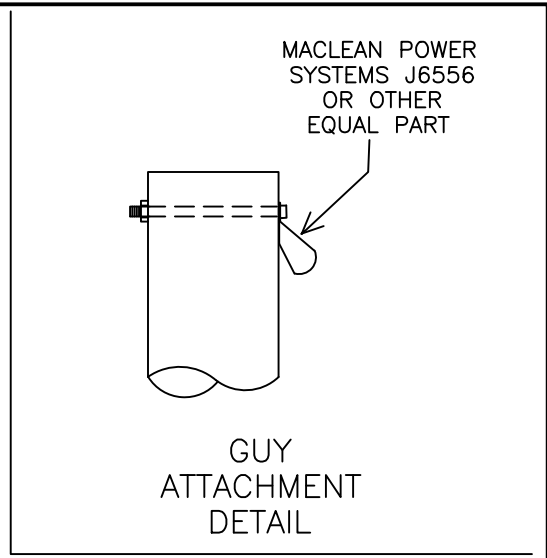
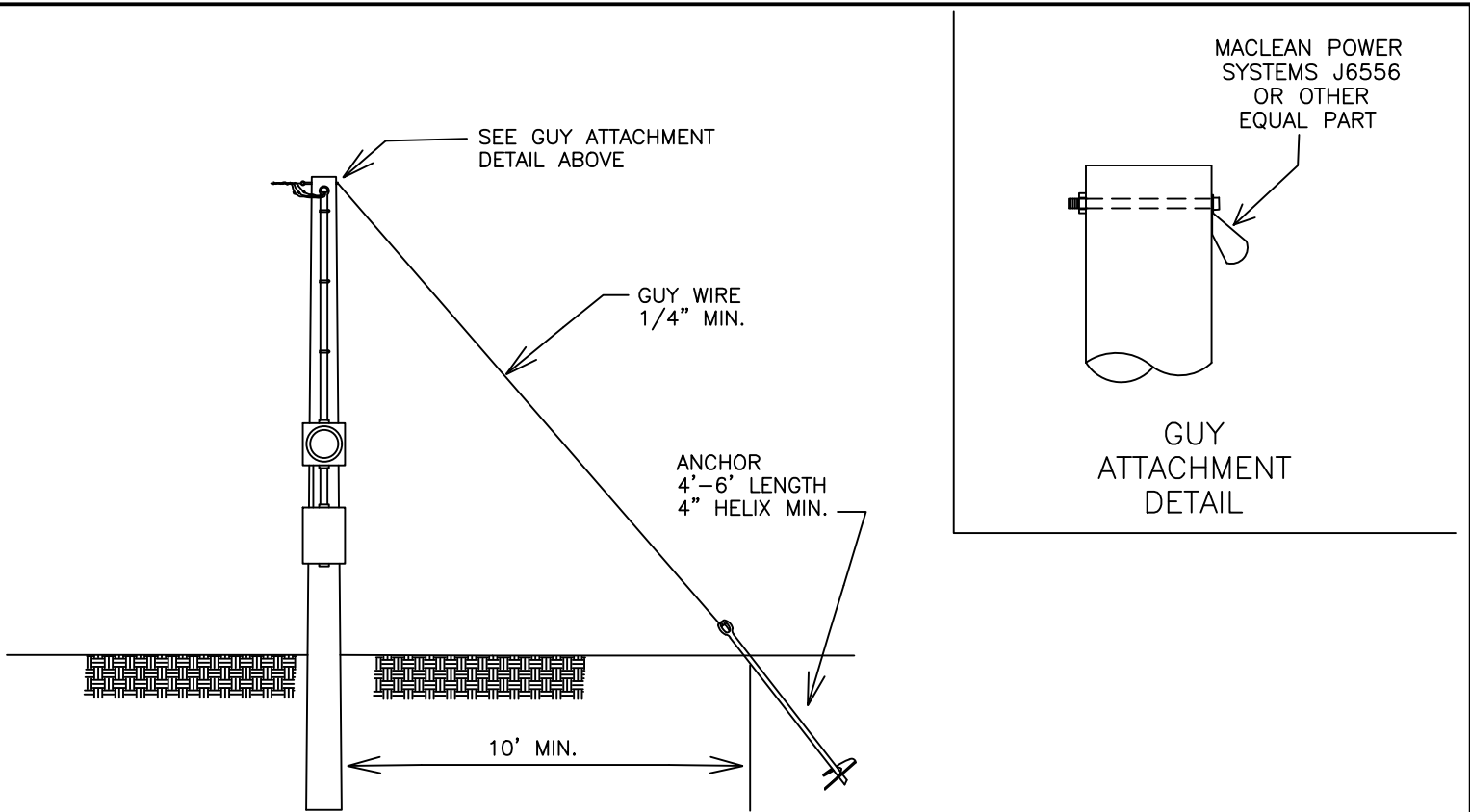

- NOTES:
1. POSITION BRACES SO THAT SERVICE DROP IS CENTERED.
 2. GUY AND ANCHOR MUST BE IN LINE WITH SERVICE DROP.

08/28/12	Rev. 09/30/20	Esfig 1A 2020.dwg
TEMPORARY SERVICE POLE GUYING AND BRACING		
FIGURE 1A	CLAY ELECTRIC COOPERATIVE, INC. KEYSTONE HEIGHTS, FLORIDA	STANDARDS FOR ELECTRIC SERVICE

AS OF 1/1/2018 LAST SPAN OF SERVICE SHALL BE UNDERGROUND

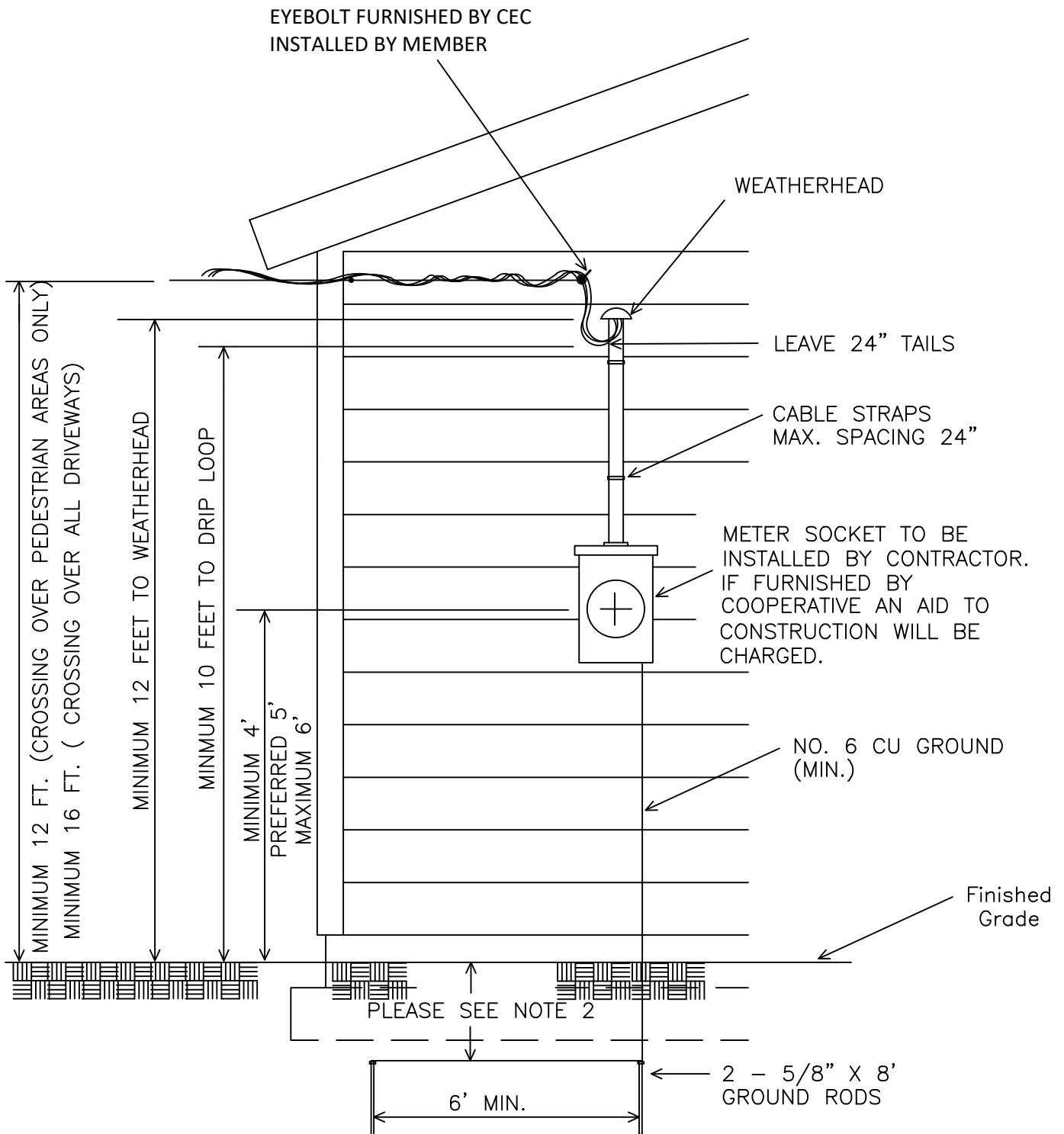

NOTES:

1. ONE 5/8" X 8' GROUND ROD MAY BE USED IF THE MEASURED RESISTANCE TO GROUND IS 25 OHMS OR LESS.
2. THE UPPER END OF THE GROUNDING ROD SHALL BE FLUSH WITH OR BELOW FINISHED GRADE UNLESS THE ABOVE GROUND END AND THE GROUNDING ROD CONDUCTOR ATTACHMENT ARE PROTECTED AGAINST PHYSICAL DAMAGE PER NEC.
- 2.1. MEMBER SHALL ADHERE TO COUNTY CODE REQUIREMENTS IN CONJUNCTION WITH THE NEC.

12/08/17	10/06/20	EsFig3 2020.dwg
TYPICAL OVERHEAD SERVICE INSTALLATION		
Figure 3	CLAY ELECTRIC COOPERATIVE, INC. KEYSTONE HEIGHTS, FLORIDA	STANDARDS FOR ELECTRIC SERVICE

AS OF 1/1/2018 LAST SPAN OF SERVICE SHALL BE UNDERGROUND

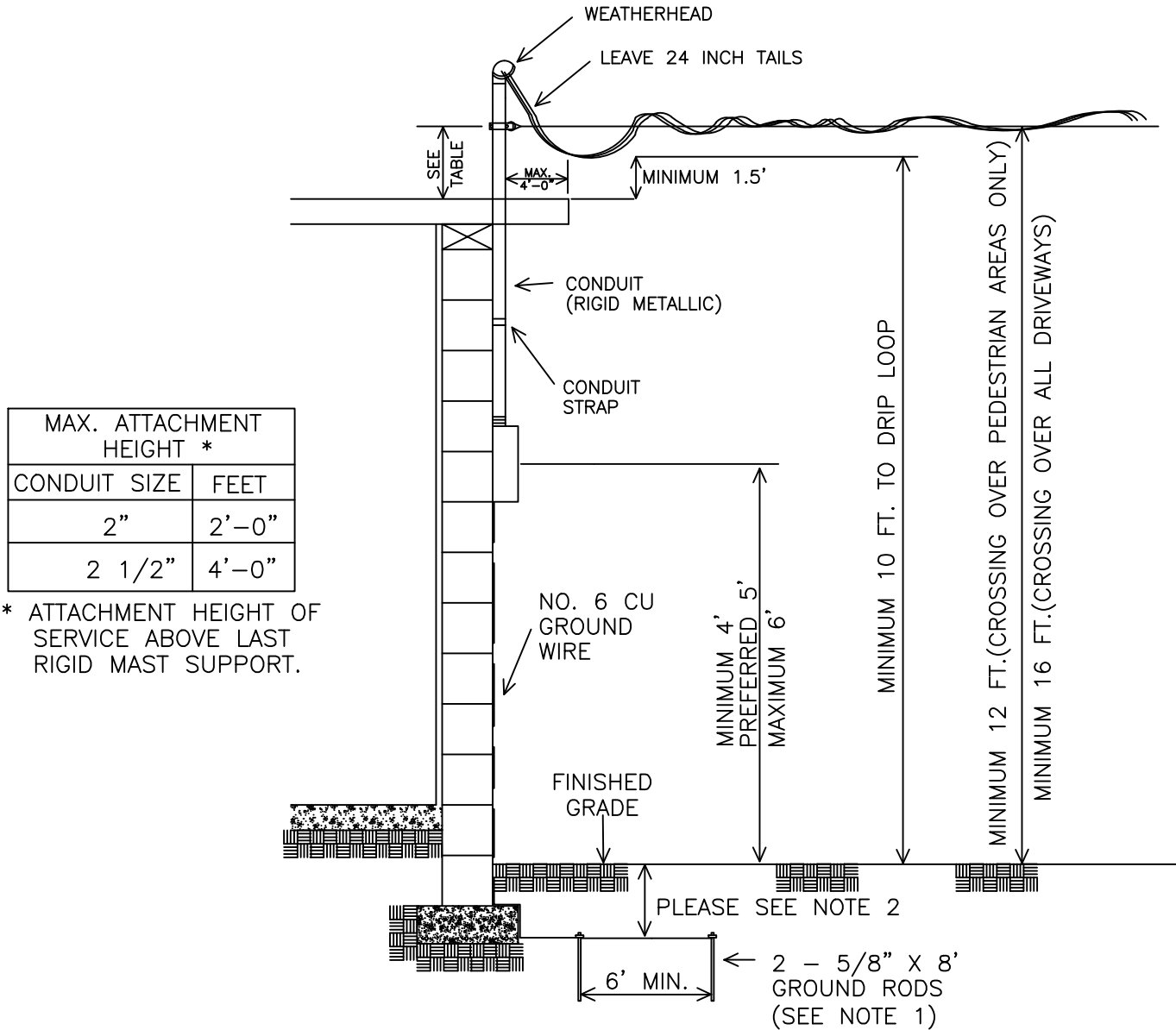

MAX. ATTACHMENT HEIGHT *	
CONDUIT SIZE	FEET
2"	2'-0"
2 1/2"	4'-0"

* ATTACHMENT HEIGHT OF SERVICE ABOVE LAST RIGID MAST SUPPORT.

NOTES:

1. ONE 5/8" X 8' GROUND ROD MAY BE USED IF THE MEASURED RESISTANCE TO GROUND IS 25 OHMS OR LESS.
2. THE UPPER END OF THE GROUNDING ROD SHALL BE FLUSH WITH OR BELOW FINISHED GRADE UNLESS THE ABOVE GROUND END AND THE GROUNDING ROD CONDUCTOR ATTACHMENT ARE PROTECTED AGAINST PHYSICAL DAMAGE PER NEC.
 - 2.1. MEMBER SHALL ADHERE TO COUNTY CODE REQUIREMENTS IN CONJUNCTION WITH THE NEC. 3. SERVICE ENTRANCE CABLE MUST NOT SPAN MORE THAN 4 FEET OF ROOF IN ANY DIRECTION.

12/08/17	10/06/20	Esfig4 2020.dwg
TYPICAL OVERHEAD SERVICE INSTALLATION		
Figure 4	CLAY ELECTRIC COOPERATIVE, INC. KEYSTONE HEIGHTS, FLORIDA	STANDARDS FOR ELECTRIC SERVICE

AS OF 1/1/2018 LAST SPAN OF SERVICE SHALL BE UNDERGROUND

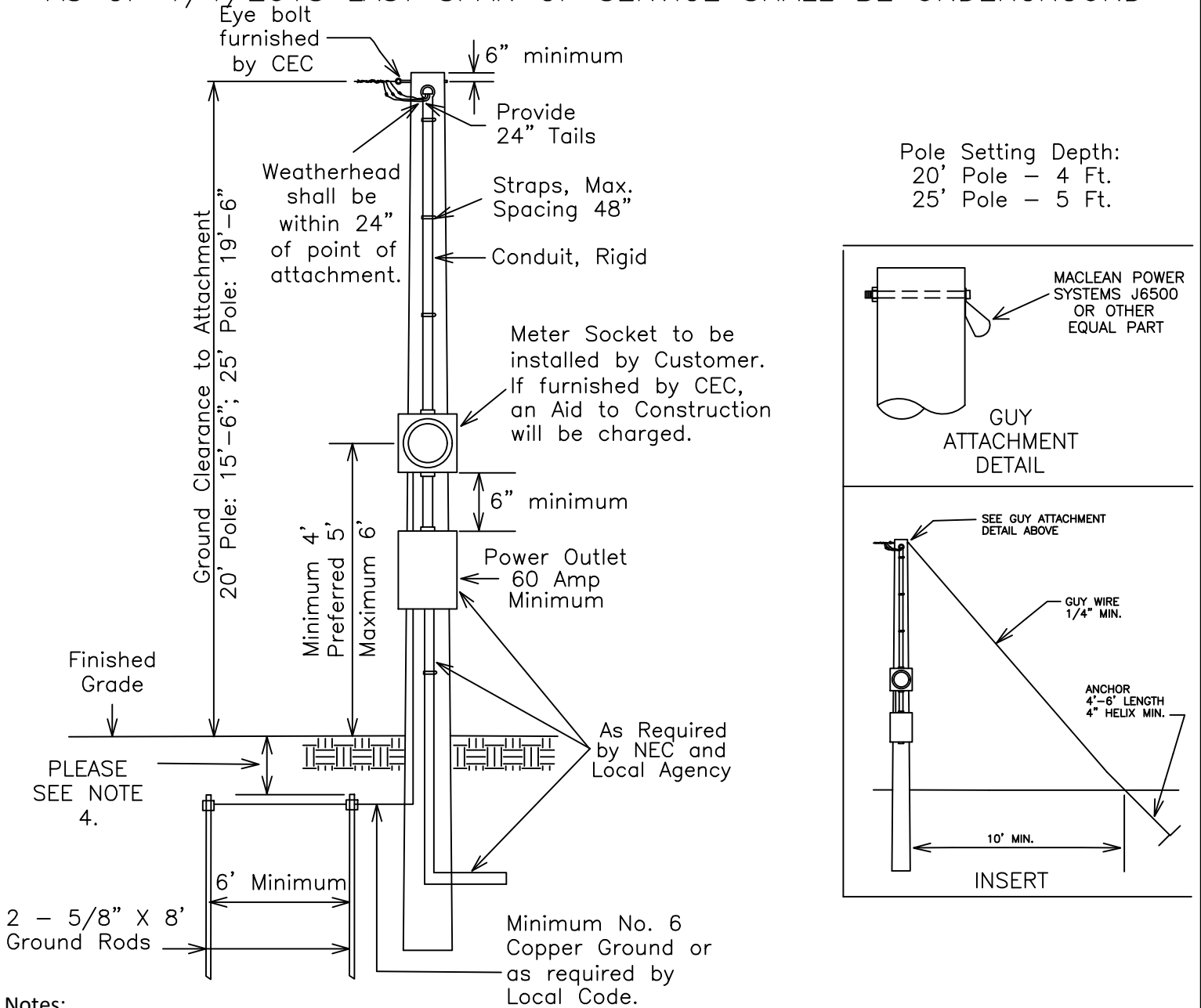

Notes:

1. Pole shall be approved pressure treated with a minimum top circumference of 15" and a minimum length of 20 feet or as required to obtain required ground clearance. Consult CEC District Engineering for pole length requirement. Minimum Ground Clearance of service wire, including drip loop, over all driveways and other areas traversed by vehicles: 16'-0". Minimum Ground Clearance of service wire, including drip loop, over areas for pedestrians only: 12'-0".
2. If service length is 50 feet or greater, guying is required. Refer to Insert detail.
3. One 5/8" x 8' ground rod may be used if the measured resistance to ground is 25 ohms or less.
4. The upper end of the grounding rod shall be flush with or below finished grade unless the above ground end and the grounding rod conductor attachment are protected against physical damage per NEC
 - 4.1. Member shall adhere to county code requirements in conjunction with the NEC.
5. Local codes that may exceed these requirements shall apply.
6. Satellite dishes, area lights and other member owned attachments shall be a minimum of 12" below the service drip loop. Clearance shall be measured to the highest point of attached object. The most current National Electrical Safety Code (NESC) requirements shall apply.

12/08/17

REV. 10/06/2020

Esfig4A 2020.dwg

TYPICAL OVERHEAD SERVICE TO MOBILE HOME, PUMP, ETC.

FIGURE 4A

CLAY ELECTRIC COOPERATIVE, INC.
KEYSTONE HEIGHTS, FLORIDA

STANDARDS FOR
ELECTRIC SERVICE

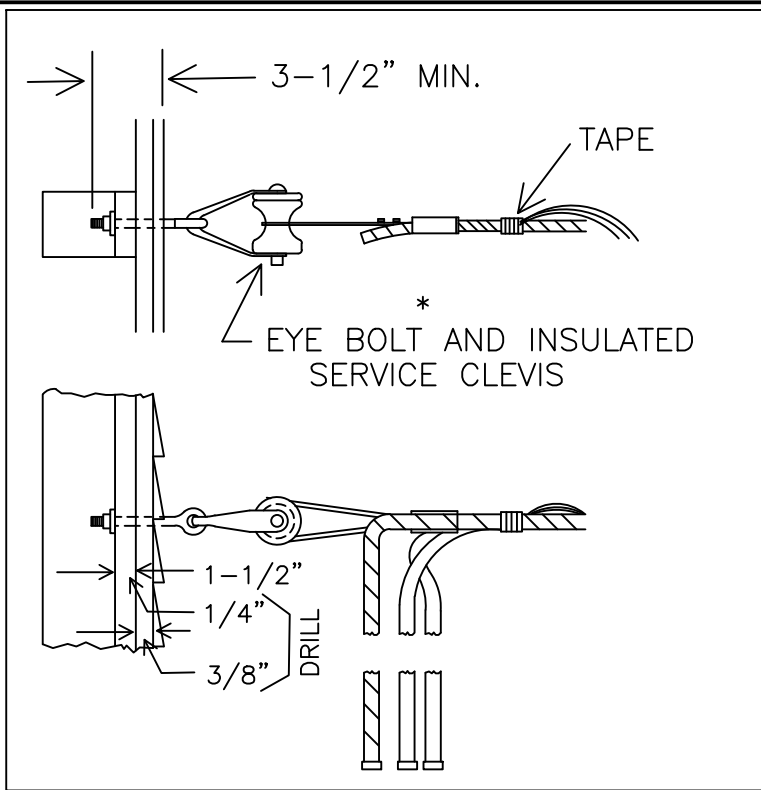

WOOD FRAME

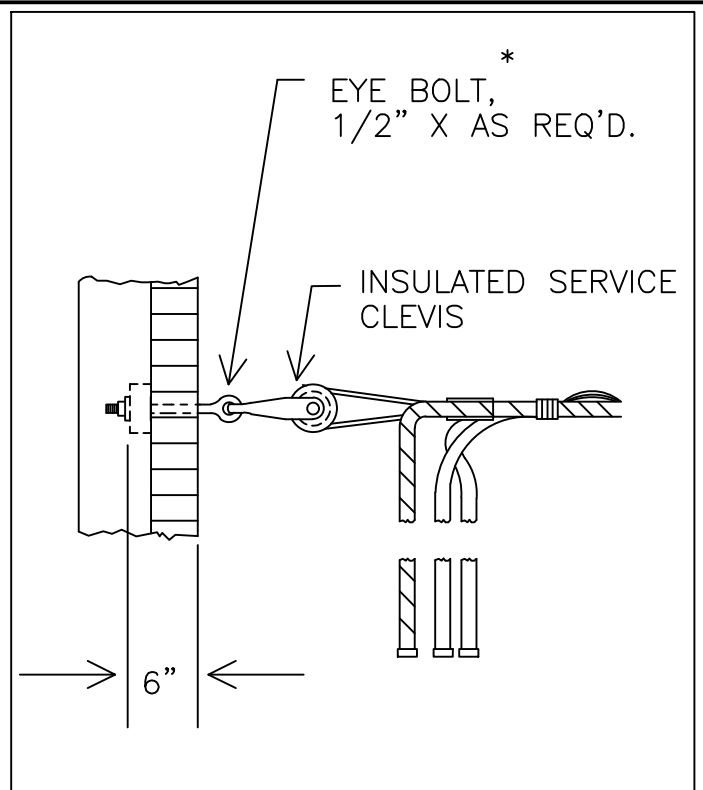

BRICK OR MASONRY

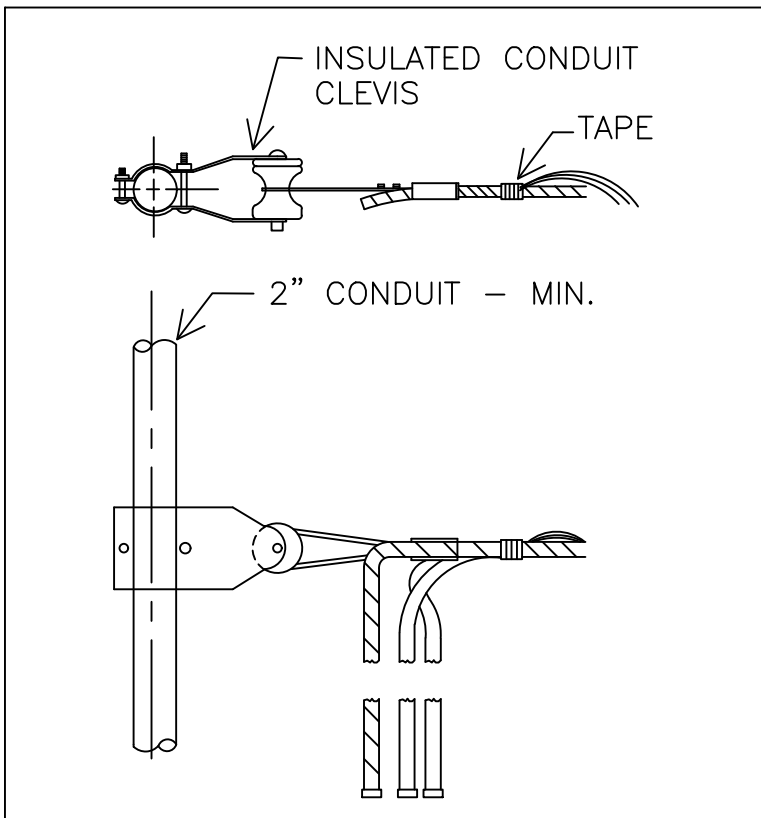

SERVICE MAST

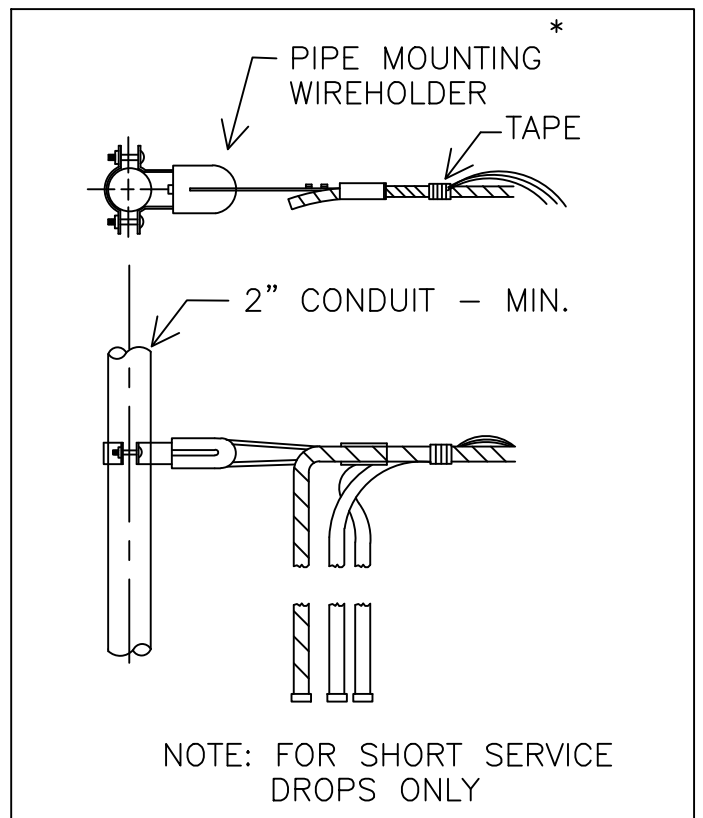

SERVICE MAST (LIGHT DUTY)

NOTE: FOR SHORT SERVICE DROPS ONLY

5/21/99

REV1. 10/06/2020

Esfig5 2020.dwg

TYPICAL OVERHEAD SERVICE ATTACHMENTS

Figure 5

CLAY ELECTRIC COOPERATIVE, INC.
KEYSTONE HEIGHTS, FLORIDA

STANDARDS FOR
ELECTRIC SERVICE

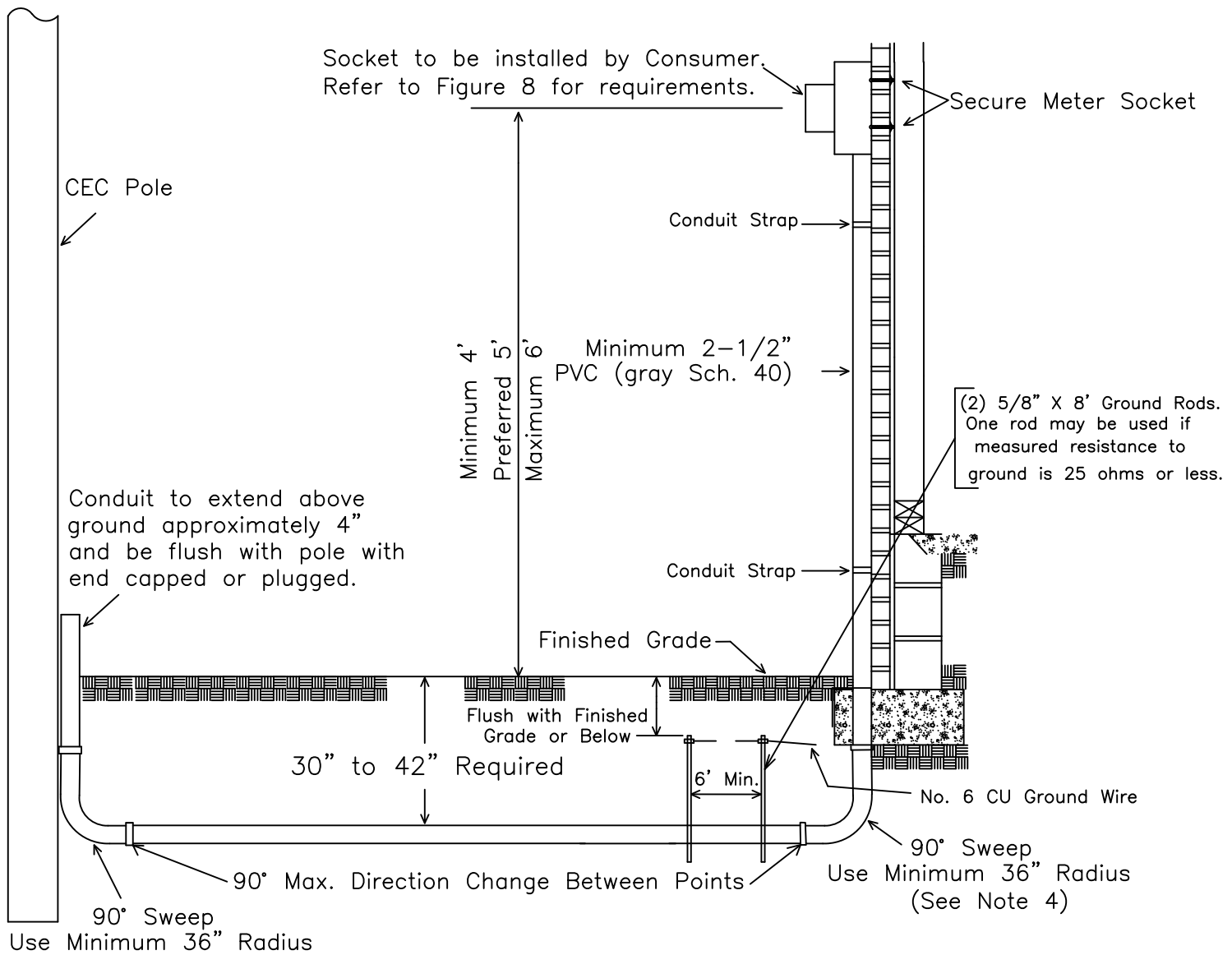

Notes:

1. Consumer to furnish and install continuous gray electrical conduit (schedule 40) from pole to meter. Meter location shall be located on same side of structure as pole and should be within 10 feet of closest corner to pole. A clear space of minimum 5 feet shall be maintained in front of meter location, with 3 feet of clearance on the sides. The meter location and conduit installation shall not be altered from these specifications without written CEC Engineering approval.
2. For single mobile home URD service installations, meter shall be mounted on pedestal (Refer to Figure 7A).
3. Any Meter Can 320A or above shall be equipped with a bypass handle.
4. Conduit requirements:
 - a. 2-1/2" minimum (Gray Schedule 40).
 - b. 36 inch minimum radius for all sweeps (elbows).
 - c. Conduit path should be most direct route from CEC pole to meter. Preferred 180° (maximum of 270°) direction change in conduit from CEC pole to meter socket.
 - d. Pull strings (nylon builders string) shall be installed in conduit by Owner from pole to meter socket.
 - e. Consumer to select clear side of pole for conduit riser that does not interfere with existing utilities.
 - f. CEC Engineer shall be consulted: for service distances greater than 200 feet from pole to meter or services larger than 320 amp or homes with greater than 4200 sq. ft. (heated & cooled) living area.
 - g. For service down pipes with foundation conflicts, two (2) 45° sweeps (36" min. radius) may be installed with a straight piece to avoid the conflict provided minimum burial depths are maintained and sweeps are installed entirely below ground line. The down pipe shall be flush with building while above ground line.

12/20/17

Rev. 02/28/2025

Esfig6 2025.dwg

Typical Residential Underground Service (320 Amp Max.)
URD Service From OH Pole

Figure 6

CLAY ELECTRIC COOPERATIVE, INC.
KEYSTONE HEIGHTS, FLORIDA

STANDARDS FOR
ELECTRIC SERVICE

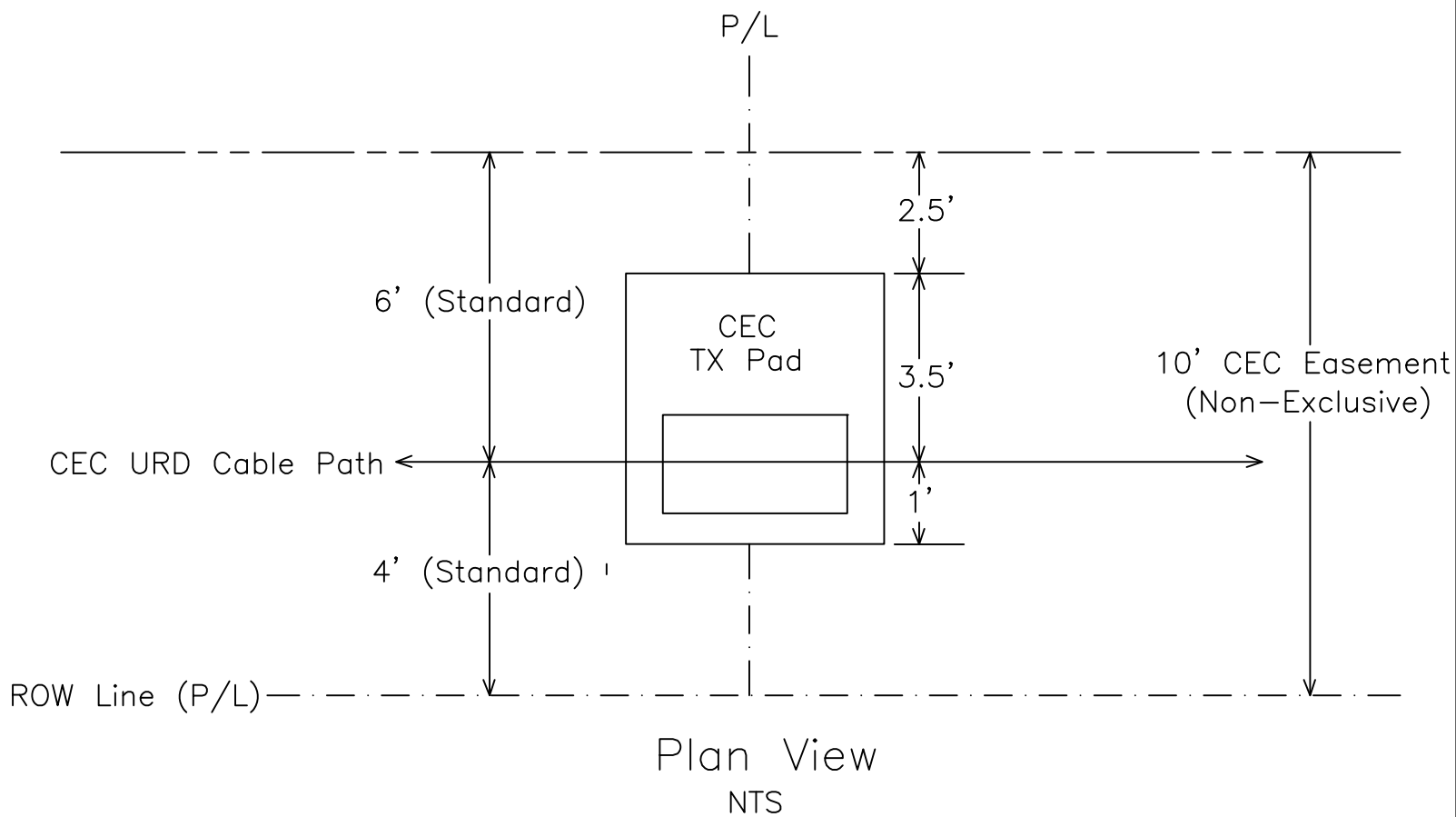

Notes:

1. CEC's standard easement width requirement is 10' for URD electric facilities within a residential development. A request for exception to this must be submitted to the District Engineer. The District Engineer will forward the request to Distribution Engineering for review. A response will then be returned to the District Engineer and he will notify the Member. If an exception is approved, the Member must include the exception as part of the plan drawings. Additional guidelines and minimum requirements related to this issue are included below.
2. It should be noted that the entire width of the CEC easement shall be cleared of trees and stumps and any other obstacles in order for CEC to install the URD cable and associated electric facilities. Final grade shall be established (+/- 6").
3. All CEC electric facilities shall lie within an easement for any new developments.
4. Minimum horizontal separation requirement for CEC electric cables: Phone and CATV: 3' Gas: 5'
5. If electric service is required on both sides of the roadway, CEC easements and electric utility allocations shall be provided on both sides of roadway.

2/6/2004

Rev. 10/15/2020

Esfing 6A-2 2020.dwg

STANDARD CEC ELECTRIC UTILITY EASEMENT REQUIREMENT
FOR URD RESIDENTIAL DEVELOPEMENTS

Figure 6A-2

CLAY ELECTRIC COOPERATIVE, INC.
KEYSTONE HEIGHTS, FLORIDA

STANDARDS FOR
ELECTRIC SERVICE

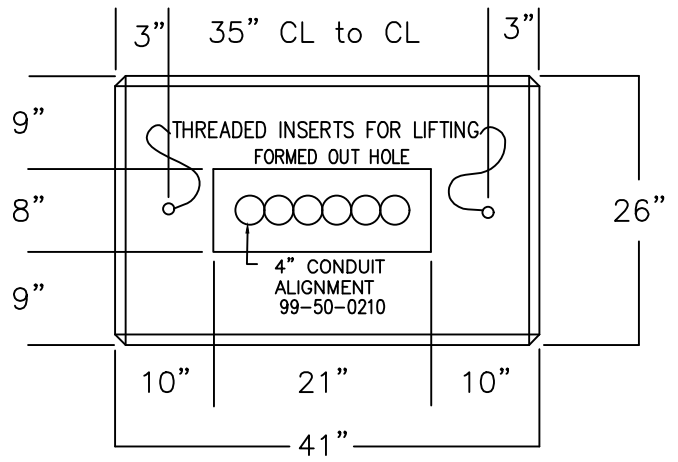
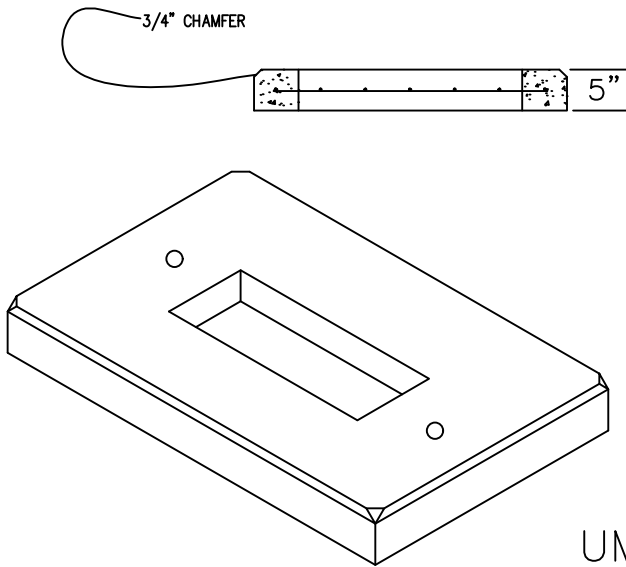

UM1-US1-2

Pad, Concrete, 41" x 26" x 5"
 3-Way or 4-Way Sectionalizing Enclosure (1 ϕ)
 CEC No. 99-50-0210
 Approximate Weight: 320 Pounds (.08 cy).

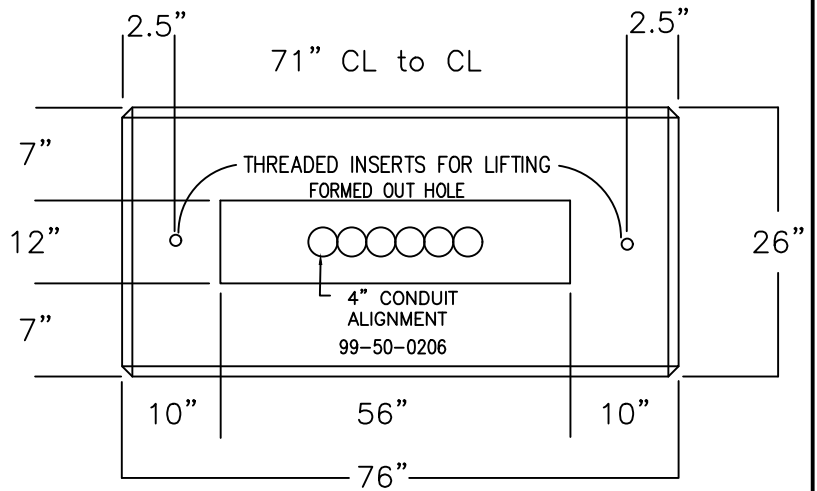
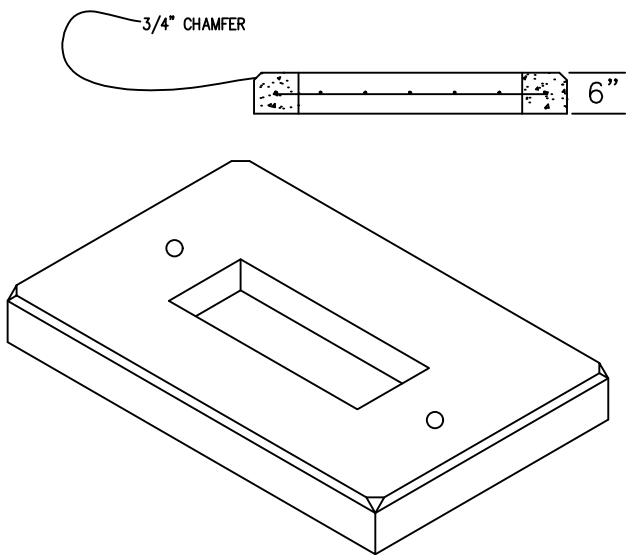

UM1-US3-4

Pad, Concrete, 76" x 26" x 6"
 3-Way or 4-Way Sectionalizing Enclosure (3 ϕ)
 CEC No. 99-50-0206
 Approximate Weight: 680 Pounds (.17 cy).

Specification: Sectionalizing Enclosure Pad

1. Concrete: 3000 psi minimum at 28 days.
2. Reinforce with 6x6- W1.4 x W1.4 welded wire mesh or #3 reinforcing bars tied on 6" centers. Add #5 rebar around formed out hole.
3. Threaded 3/4" insert(s) suitable for lifting to allow for balanced pick up.
4. CEC No. to be stenciled (not embedded) on pad in minimum 2" lettering as indicated on drawing.

12/27/01	Rev 10/09/20	Esfig6A-3 2020.dwg
Pad Assemblies (Concrete) for 1 ϕ and 3 ϕ Sectionalizing Enclosures		
Figure 6A-3	CLAY ELECTRIC COOPERATIVE, INC. KEYSTONE HEIGHTS, FLORIDA	STANDARDS FOR ELECTRIC SERVICE

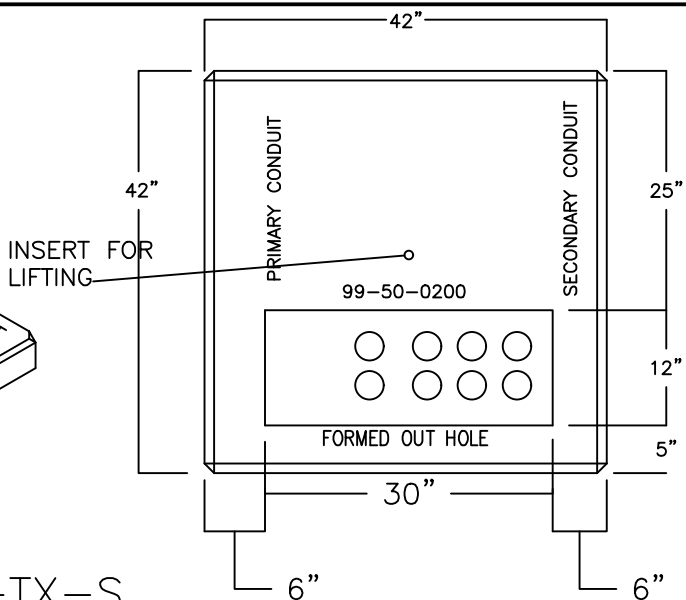
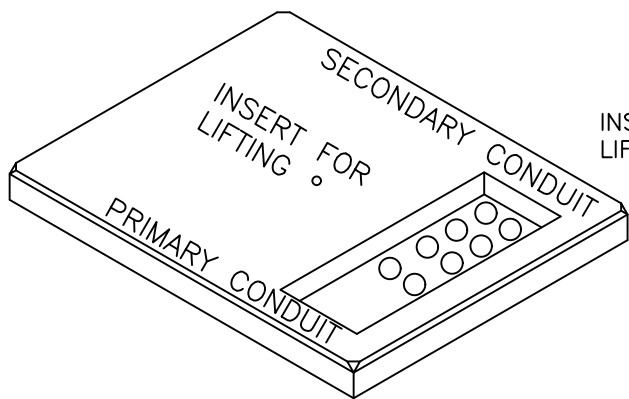
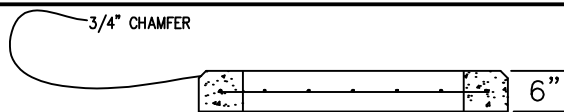

UM1-TX-S

Pad, Concrete, 42" x 42" x 6"
 25 to 75 kVA Padmount Tx (1Ø)
 CEC No. 99-50-0200
 Approximate weight: 600 pounds (.15cy).

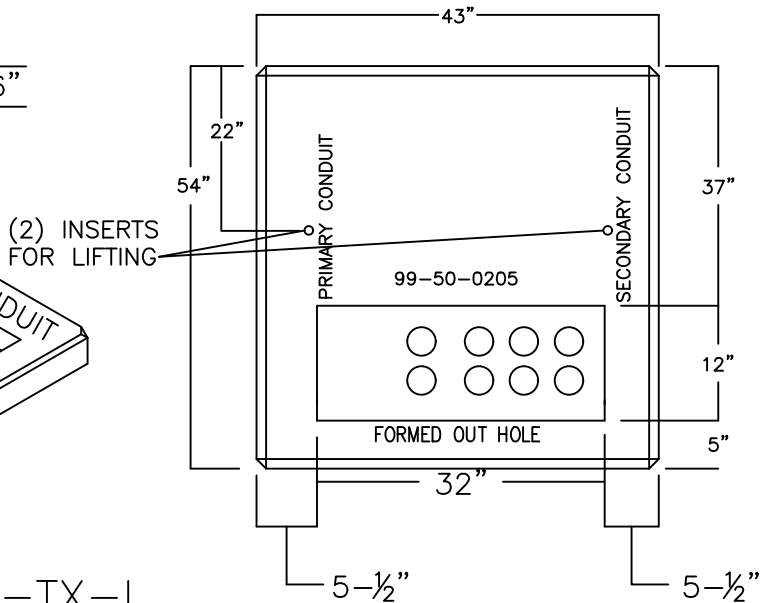
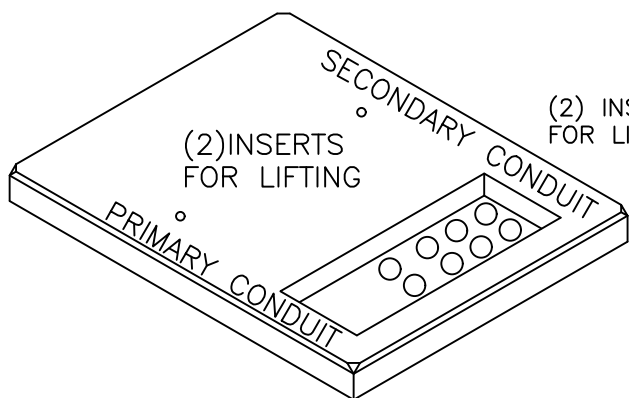

UM1-TX-L

Pad, Concrete, 43" x 54" x 6"
 100 to 167 kVA Padmount Tx (1Ø)
 CEC No. 99-50-0205

Specification: Single Phase Transformer Pad

1. Concrete: 3000 psi minimum at 28 days
2. Reinforce with 6x6- W1.4 x W1.4 welded wire mesh or #3 reinforcing bars tied on 6" centers. Add #5 rebar around formed out hole.
3. Threaded 3/4" insert(s) suitable for lifting to allow for balanced pick up.
4. CEC No. to be stenciled (not embedded) on pad in minimum 2" lettering as indicated on drawing.

12/04/18

10/09/20

Esfig6A-4 2020.dwg

Pad Assemblies (Concrete) for Single Phase Padmount Transformers

Figure 6A-4

CLAY ELECTRIC COOPERATIVE, INC.
 KEYSTONE HEIGHTS, FLORIDA

STANDARDS FOR
 ELECTRIC SERVICE

Notes:

1. Consumer to furnish and install continuous gray electrical conduit from service stub to meter complete with tie in.
2. Conduit Requirements:
 - a. Depth shall be 30" to 42"
 - b. Min. Size: 2-1/2" PVC (Gray Sch. 40)
 - c. Minimum 36" radius elbows (sweeps) at all directional changes.
 - d. Conduit path should be most direct route from service stub at lot corner to sweep at meter socket. Directional changes from service stub to meter socket shall be maximum of 270° (180 preferred).
 - f. All conduit shall be sealed to prevent contamination.
3. A clear space of minimum 5'-0" shall be maintained in front of meter.
4. Written approval by CEC Engineering required to deviate from specifications.

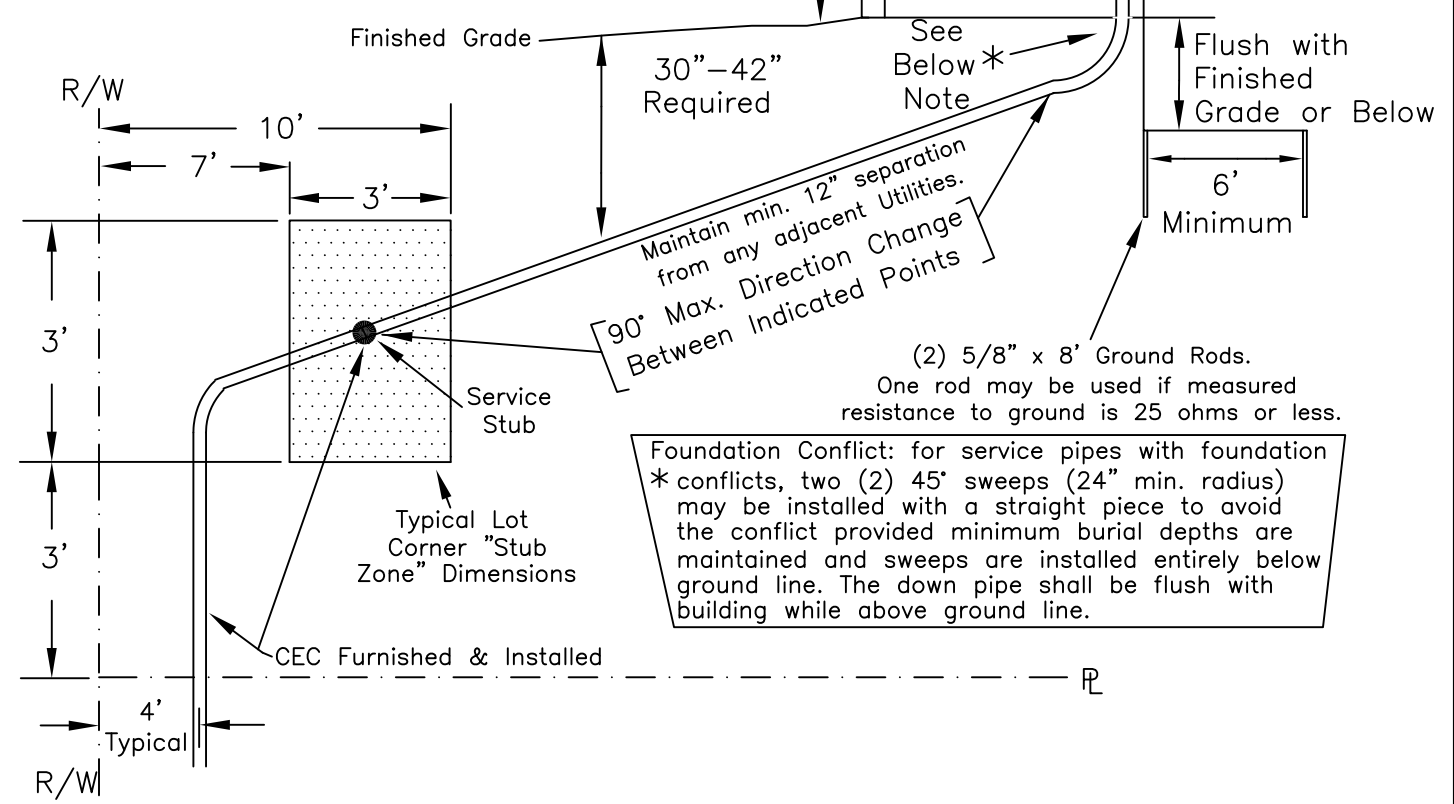
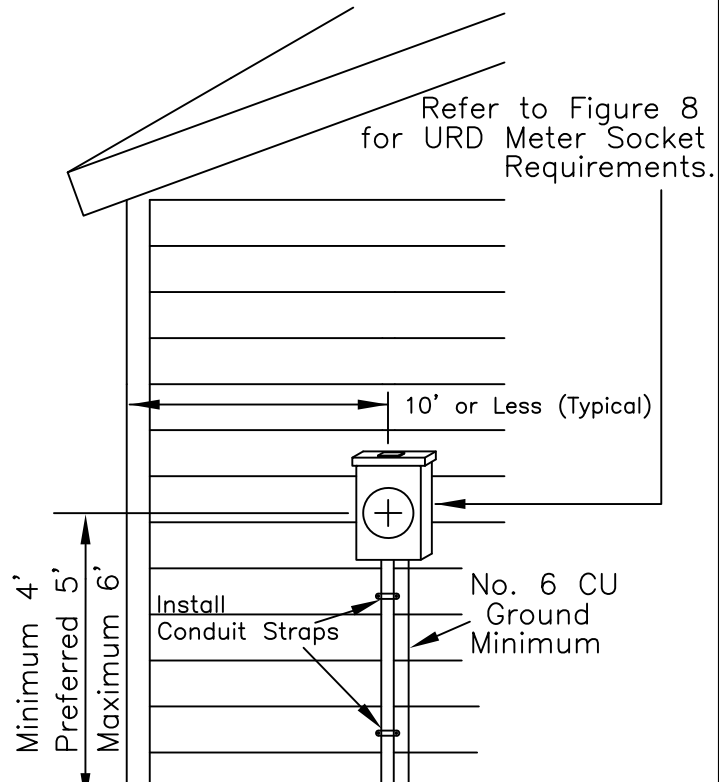

(2) 5/8" x 8' Ground Rods.
 One rod may be used if measured resistance to ground is 25 ohms or less.

Foundation Conflict: for service pipes with foundation * conflicts, two (2) 45° sweeps (24" min. radius) may be installed with a straight piece to avoid the conflict provided minimum burial depths are maintained and sweeps are installed entirely below ground line. The down pipe shall be flush with building while above ground line.

12/20/17	Rev. 02/28/2025	Esfig 6B 2025.dwg
CONSTRUCTION REQUIREMENTS FOR TYPICAL URD SUBDIVISION SERVICE (320 AMP MAX.) TIE-IN		
Figure 6B	CLAY ELECTRIC COOPERATIVE, INC. KEYSTONE HEIGHTS, FLORIDA	STANDARDS FOR ELECTRIC SERVICE

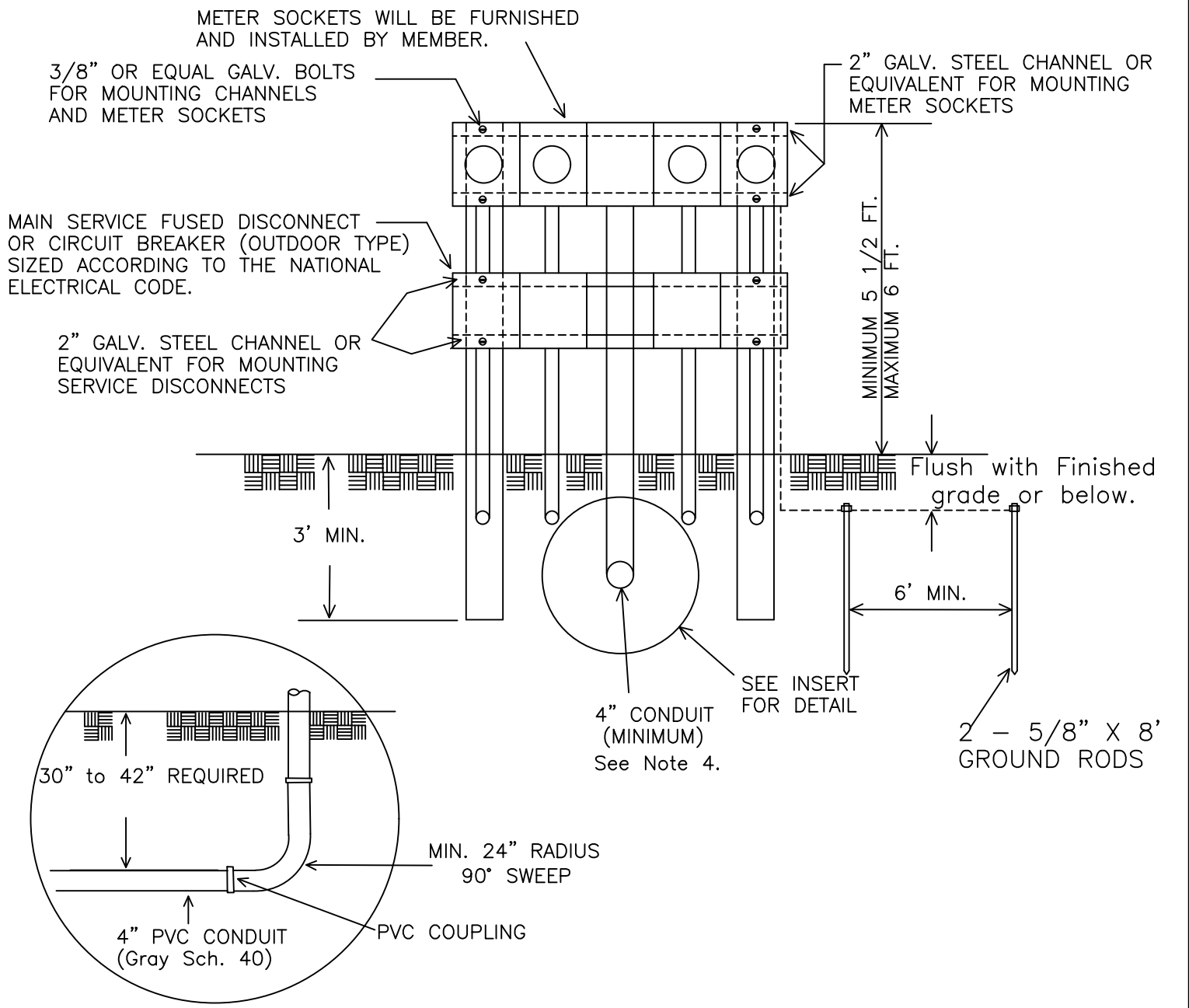

- NOTES**
1. MEMBER TO PROVIDE CONTINUOUS CONDUIT FROM CEC FACILITY TO METER COMPLETE WITH SWEEPS. CONSULT CEC ENGINEERING FOR METER LOCATION.
 2. ONE 5/8" X 8' GROUND ROD MAY BE USED IF THE MEASURED RESISTANCE TO GROUND IS 25 OHMS OR LESS.
 3. THE UPPER END OF THE GROUNDING ROD SHALL BE FLUSH WITH OR BELOW FINISHED GRADE UNLESS THE ABOVE GROUND END AND THE GROUNDING ROD CONDUCTOR ATTACHMENT ARE PROTECTED AGAINST PHYSICAL DAMAGE PER NEC.
 - 3.1. MEMBER SHALL ADHERE TO COUNTY CODE REQUIREMENTS IN CONJUNCTION WITH THE NEC.
 4. METER SOCKETS AND ALL OTHER MATERIAL TO BE FURNISHED AND INSTALLED BY MEMBER IN ACCORDANCE WITH NATIONAL ELECTRIC CODE.
 5. POST TO BE CONSTRUCTED OF REINFORCED CONCRETE 5"X5" OR 2" GALV. STEEL PIPE WITH 2" CONCRETE ENCASEMENT BELOW GROUND LEVEL.
 6. FOR A TWO (2) UNIT SERVICE, USE MINIMUM 3" PVC (Gray Sch. 40).

12/20/17	Rev. 10/15/2020	Esfig 7 2020.dwg
MOBILE HOME PARK SERVICE FOUR UNIT UNDERGROUND SUPPLY		
Figure 7	CLAY ELECTRIC COOPERATIVE, INC. KEYSTONE HEIGHTS, FLORIDA	STANDARDS FOR ELECTRIC SERVICE

Meter socket to be installed by Consumer. Refer to Figure 8 for requirements.

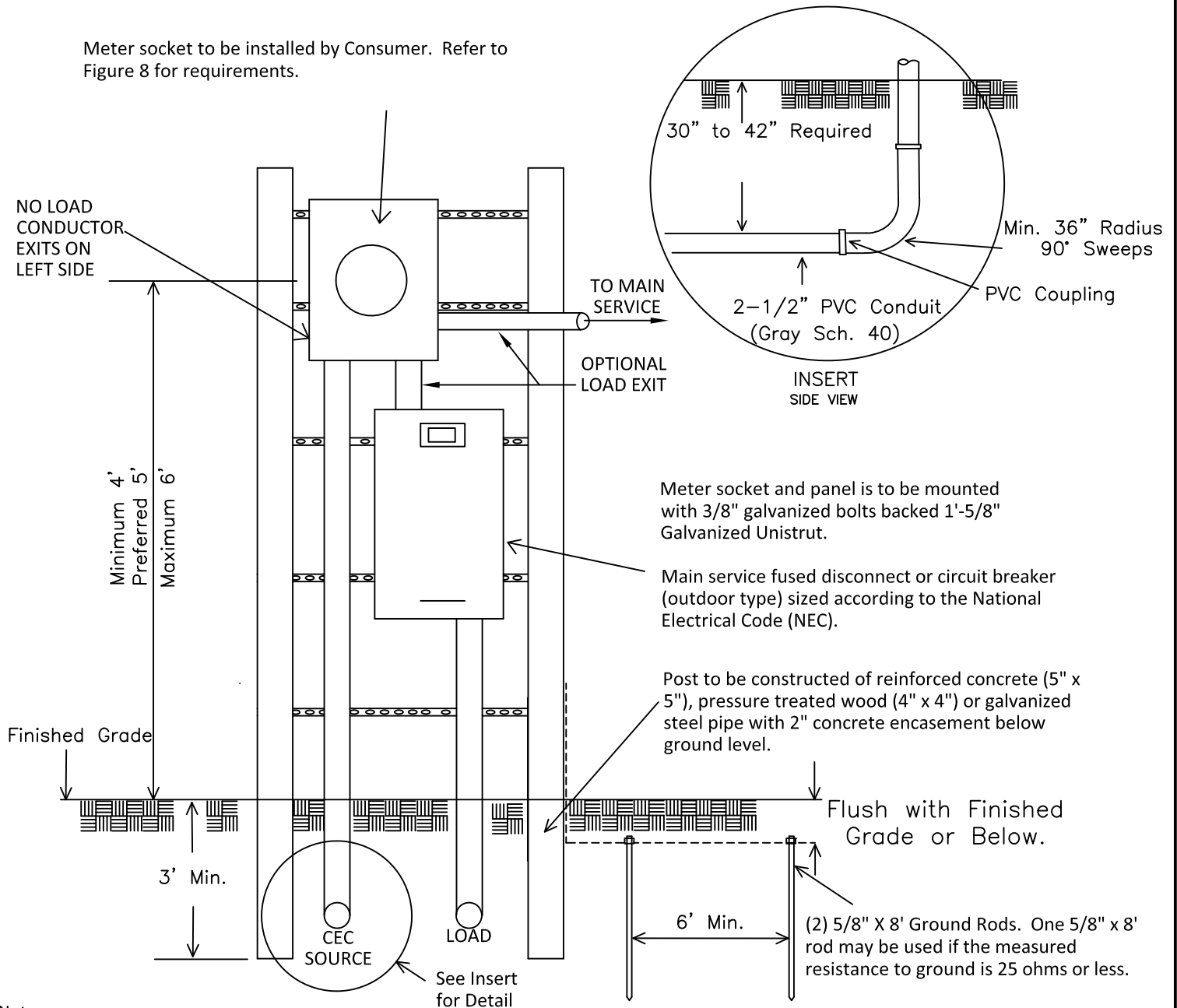

Notes:

1. Consumer to furnish and install continuous gray electrical conduit (schedule 40) from pole to meter. Meter location shall be located on same side of structure as pole. A clear space of minimum 5 feet shall be maintained in front of meter location. The meter pedestal and conduit installation shall not be altered from these specifications without written approval from CEC Engineering.
2. Conduit Requirements:
 - a. Minimum 2-1/2" PVC (Gray Schedule 40) for 200 Amp panels. Minimum 3" PVC (Gray Schedule 40) for 320 Amp panels.
 - b. 36 inch minimum radius for all sweeps(elbows).
 - c. Conduit path should be most direct path from pole to meter. 270° Maximum (180° preferred) direction change in conduit from CEC pole to meter.
 - d. Pull strings (nylon builders string) shall be installed in conduit from pole to meter socket.
 - e. Consumer to select clear side of pole for conduit riser that does not interfere with existing utilities. At pole, conduit to extend above ground approximately 4" and be flush with pole with end capped or plugged.
3. Meter sockets and all other materials to be installed by Consumer in accordance with the National Electrical Code (NEC).
4. Consult CEC Engineering for services larger than 320 amps or with service lengths greater than 200' in length.
5. Any Meter Can 320A or above shall be equipped with a bypass handle.
6. Consumers load conductors shall never exit on the left hand side of the meter can and not cross source side conductors.

09/30/92

Rev. 02/28/25

Esfig7A 2025.dwg

SINGLE SERVICE (320 AMP MAX) UNDERGROUND SUPPLY (PEDESTAL MOUNT)

FIGURE 7A

CLAY ELECTRIC COOPERATIVE, INC.
KEYSTONE HEIGHTS, FLORIDA

STANDARDS FOR
ELECTRIC SERVICE

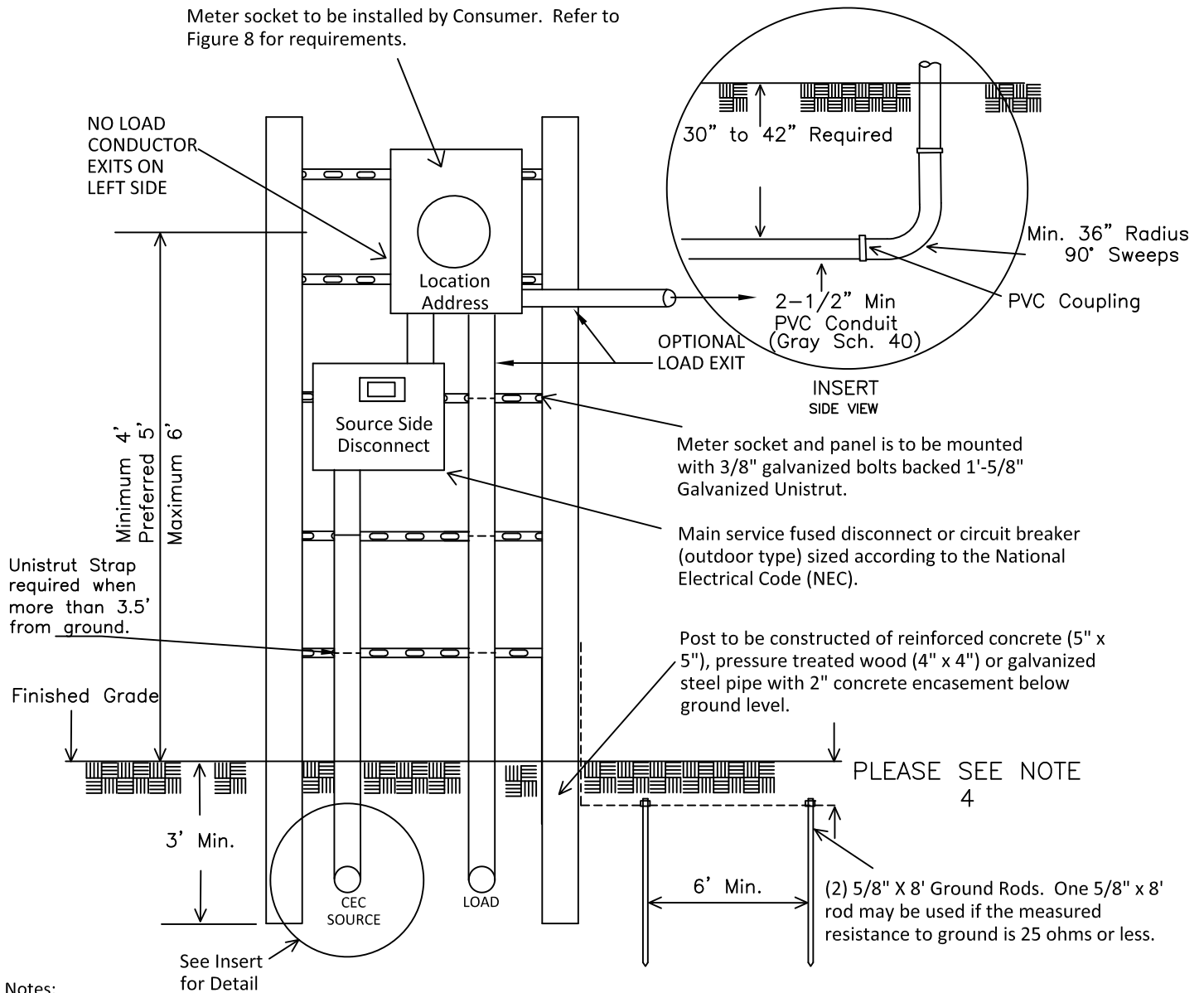

- Notes:
1. Consumer to furnish and install continuous gray electrical conduit (schedule 40) from pole to meter. Meter location shall be located on same side of structure as pole. A clear space of minimum 5 feet shall be maintained in front of meter location. The meter pedestal and conduit installation shall not be altered from these specifications without written approval from CEC Engineering.
 2. Conduit Requirements:
 - a. Minimum 2-1/2" PVC for 200 Amp panels, Min. 3" PVC for 320 Amp panels (Gray Schedule 40). 36 inch min. radius for all sweeps(elbows).
 - b. Conduit path should be most direct path from pole to meter. 270° Maximum (180° preferred) direction change in conduit from CEC pole to meter.
 - c. Pull strings (nylon builders string) shall be installed in conduit from pole to meter socket.
 - d. Consumer to select clear side of pole for conduit riser that does not interfere with existing utilities. At pole, conduit to extend above ground approximately 4" and be flush with pole with end capped or plugged.
 3. Meter sockets and all other materials to be installed by Consumer in accordance with the National Electrical Code (NEC).
 4. The upper end of the grounding rod shall be flush with or below finished grade unless the above ground end and the grounding rod conductor attachment are protected against physical damage per NEC.
 - 4.1. Consumer shall adhere to county code requirements in conjunction with the NEC.
 5. Consult CEC Engineering for all 3Ø services and 1Ø services larger than 320 amps or with service lengths greater than 200' in length.
 6. Any Meter Can 320A or above shall be equipped with a bypass handle.
 7. **All Meter Cans 480V Phase to Phase require a Main Disconnect on the source side of the meter per CEC Engineering & Operations.**
 8. Consumers load conductors shall never exit on the left hand side of the meter can and not cross the source side conductors.

09/30/92

Rev. 04/09/26

Esfig7B 2025.dwg

480V SERVICE (320 AMP MAX) UNDERGROUND SUPPLY (PEDESTAL MOUNT)

FIGURE 7B

CLAY ELECTRIC COOPERATIVE, INC.
KEYSTONE HEIGHTS, FLORIDA

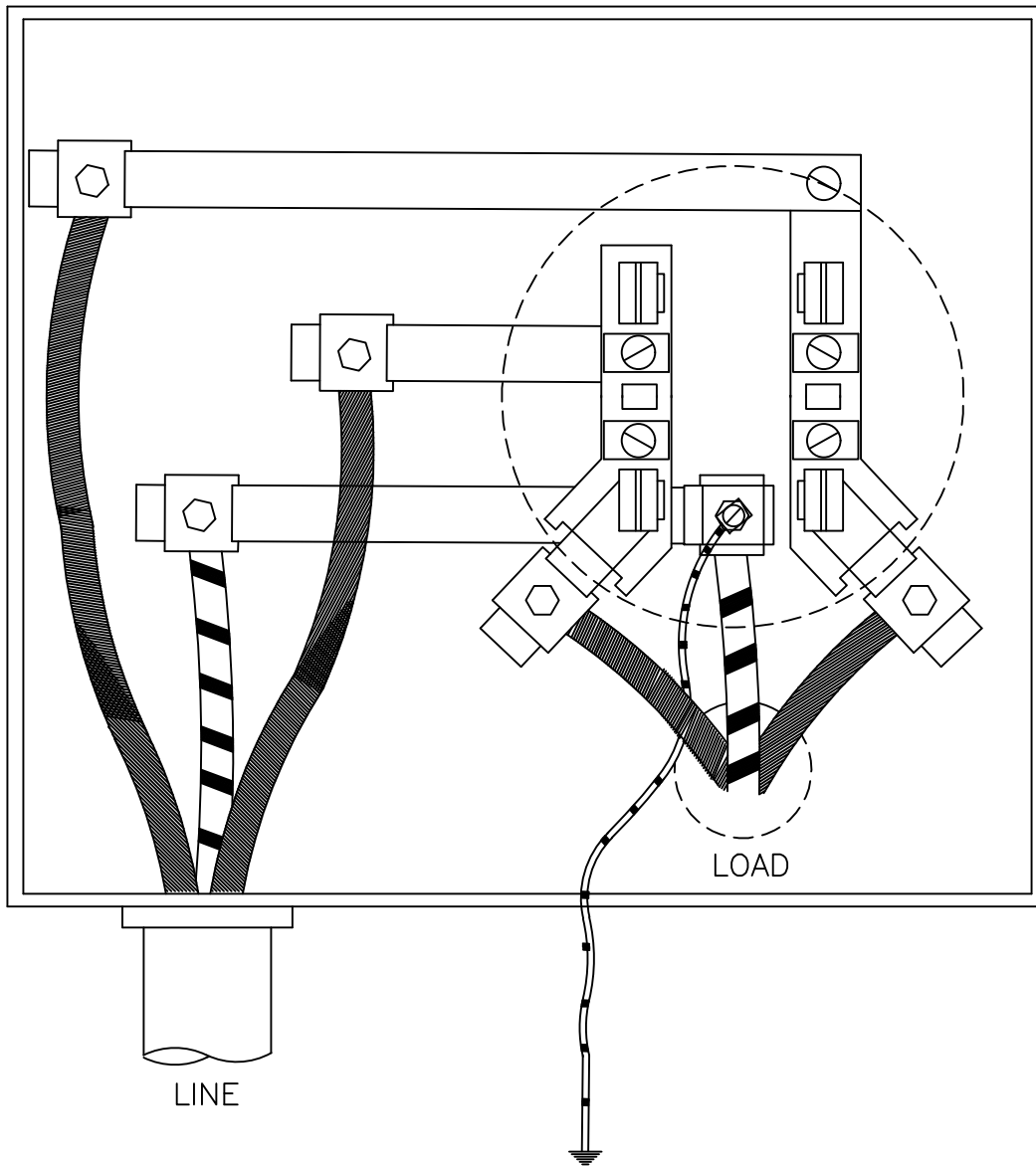

Note: The 320A meter socket shall be equipped with a bypass handle.

- CEC URD Meter Sockets Manufacturers(1-Phase: 4-Terminal):
- | | |
|---------------------------|---------------------------|
| 200 Amp (CEC #70-05-0150) | 320 Amp (CEC #70-19-0475) |
| Durham | Durham |
| Landis & Gyr | Landis & Gyr |
| Milbank | Milbank |

The above manufacturers are approved for use on 200A & 320A single phase URD services. Contact your local Clay Electric District Office to purchase or to get current catalog numbers for the approved manufacturers. Local Code which exceed these requirements shall apply. Contact the local permitting agency.

10/05/09	Rev. 10/16/2020	Esfig 8 2020.dwg
THREE WIRE-SINGLE PHASE 120/240 VOLT UNDERGROUND (URD) METER SOCKET (200A AND 320A TYPE)		
FIGURE 8	CLAY ELECTRIC COOPERATIVE, INC. KEYSTONE HEIGHTS, FLORIDA	STANDARDS FOR ELECTRIC SERVICE

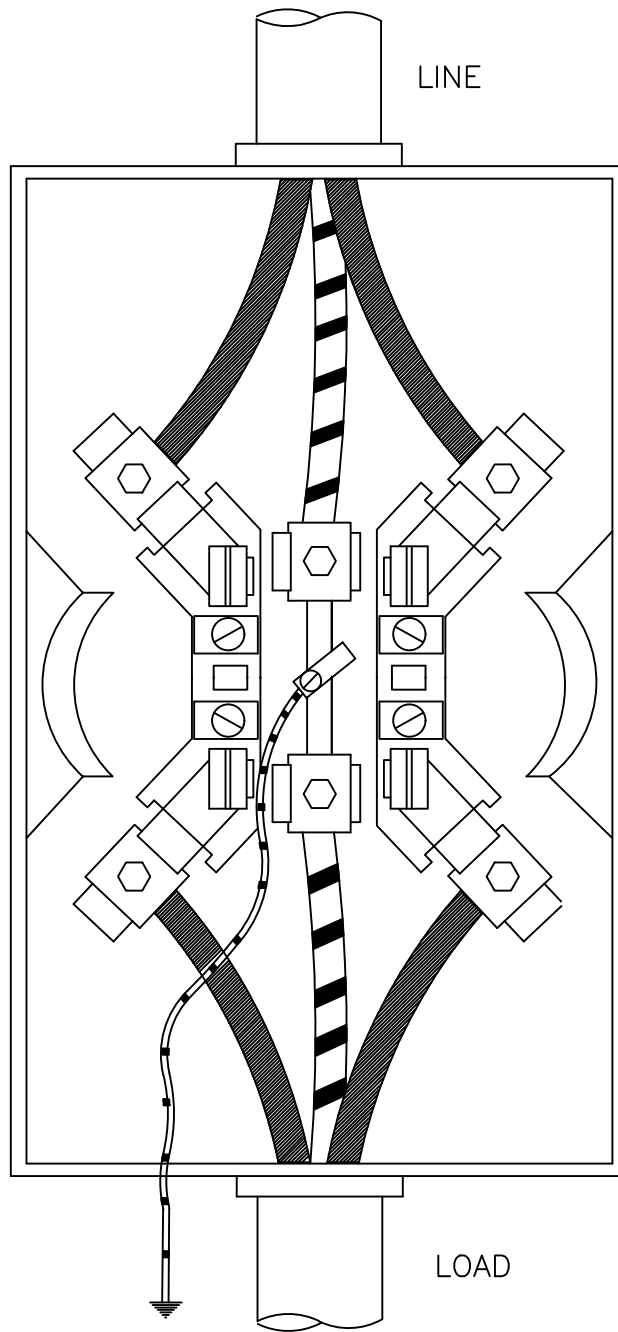

CEC Overhead Meter Socket Manufacturers:

200 Amp (CEC #70-05-0150)
 Durham
 Landis & Gyr
 Milbank

320 Amp (CEC #70-19-0475)
 Durham
 Landis & Gyr
 Milbank

Note: The 320A meter socket shall be equipped with a bypass handle.

The above manufacturers are approved for use on 200A & 320A 3-wire single phase "Overhead" type services. Contact your local Clay Electric District Office to purchase or to get current catalog numbers. Local Code which shall exceed these requirements shall apply. Contact the local permitting agency.

10/05/09	Rev. 10/16/20	Esfig 9 2020.dwg
THREE WIRE-SINGLE PHASE 120/240 VOLT OVERHEAD (OH) METER SOCKET (200A AND 320A TYPE)		
FIGURE 9	CLAY ELECTRIC COOPERATIVE, INC. KEYSTONE HEIGHTS, FLORIDA	STANDARDS FOR ELECTRIC SERVICE

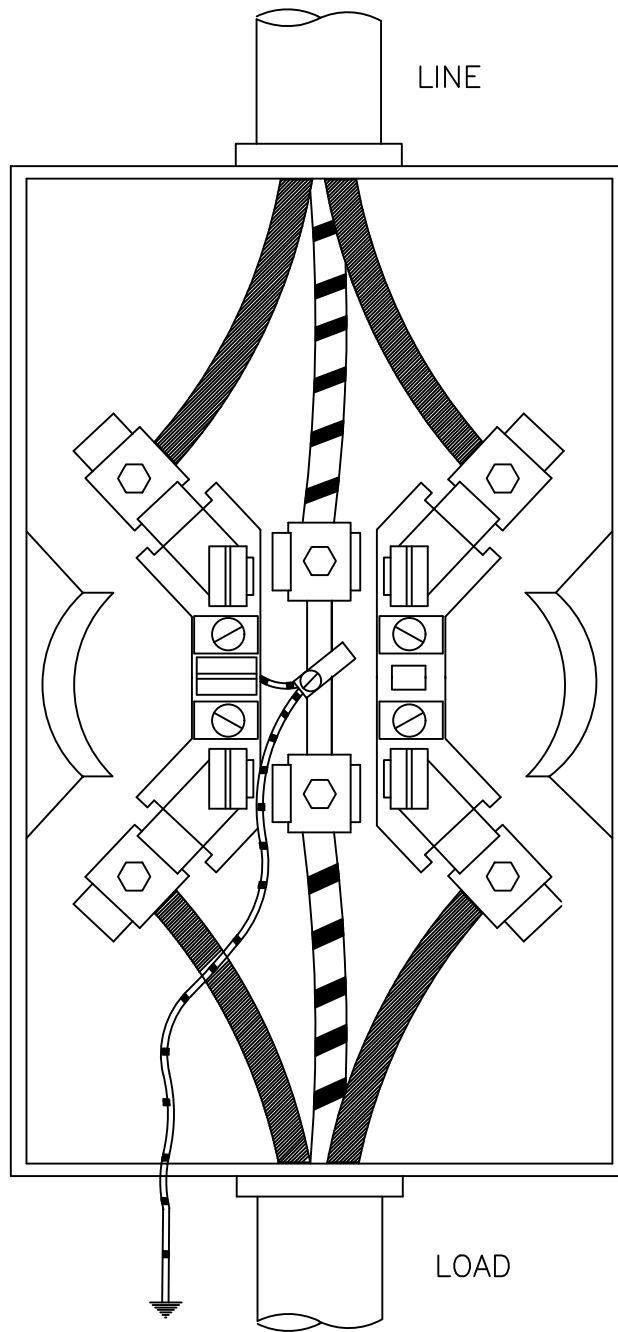

CEC Overhead Meter Socket Manufacturers:

200 Amp (CEC #70-05-0125)	320 Amp (CEC #70-05-0225)
Anchor	Durham
Durham	Landis & Gyr
Landis & Gyr	Milbank
Milbank	

Note: The 320A meter socket shall be equipped with a bypass handle.

The above manufacturers are approved for use on 200A & 320A 3-wire single phase "Overhead" type services. Contact your local Clay Electric District Office to purchase or to get current catalog numbers. Local Code which shall exceed these requirements shall apply. Contact the local permitting agency.

10/05/09	Rev. 10/16/20	Esf10 2020.dwg
THREE WIRE-SINGLE PHASE 120/208V Network Meter Socket (200A)		
FIGURE 10	CLAY ELECTRIC COOPERATIVE, INC. KEYSTONE HEIGHTS, FLORIDA	STANDARDS FOR ELECTRIC SERVICE

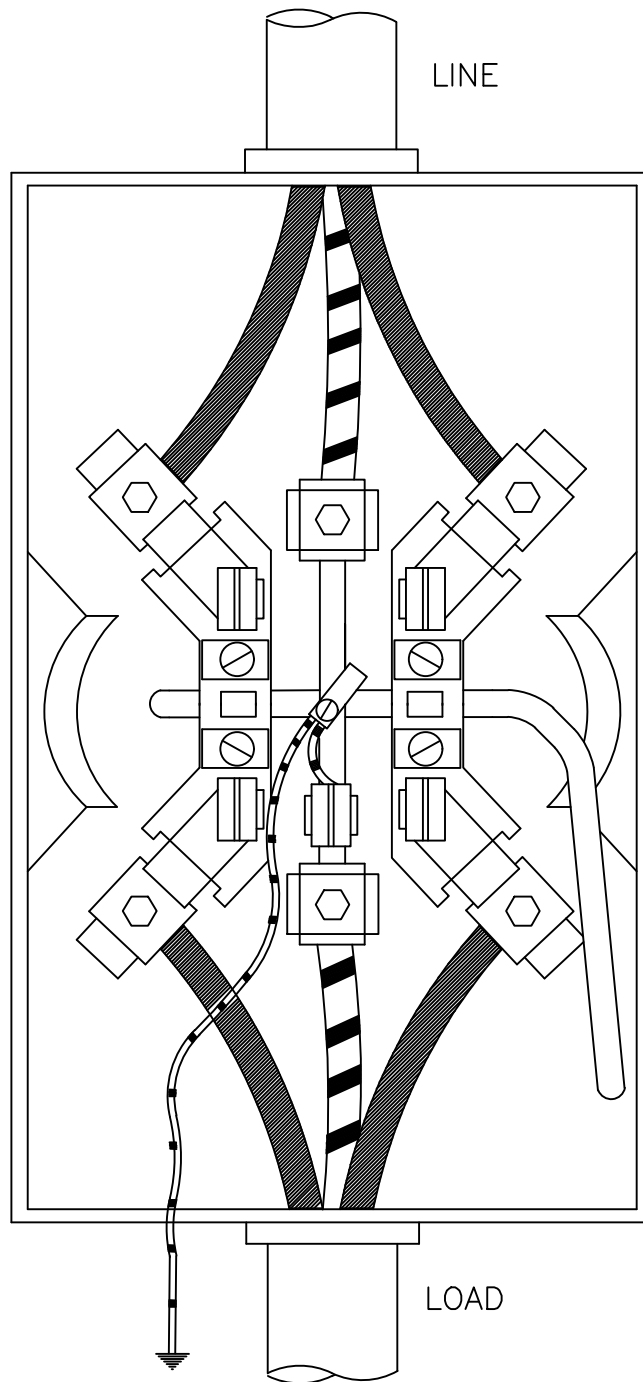

CEC Approved Meter Socket Manufacturers:

320 Amp (CEC #70-05-0225)

Landis & Gyr

Milbank

NOTES:

1. For Class 200 Meter, fifth jaw shall be in the 9 O'clock position.
2. For Class 320 Meter, fifth jaw shall be in the 6 O'Clock position.
3. **All 320A meter sockets shall be equipped with a bypass handle.**

The above manufacturers are approved for use on 320A 3-wire single phase 120/208 volt services. Contact your local Clay Electric District Office to purchase or to get current catalog numbers. Local Code which shall exceed these requirements shall apply. Contact the local permitting agency.

09/30/92

Rev. 10/20/20

Esf10A 2020.dwg

THREE WIRE SINGLE PHASE 120/208V NETWORK METER SOCKET

FIGURE 10A

CLAY ELECTRIC COOPERATIVE, INC.
KEYSTONE HEIGHTS, FLORIDA

STANDARDS FOR
ELECTRIC SERVICE

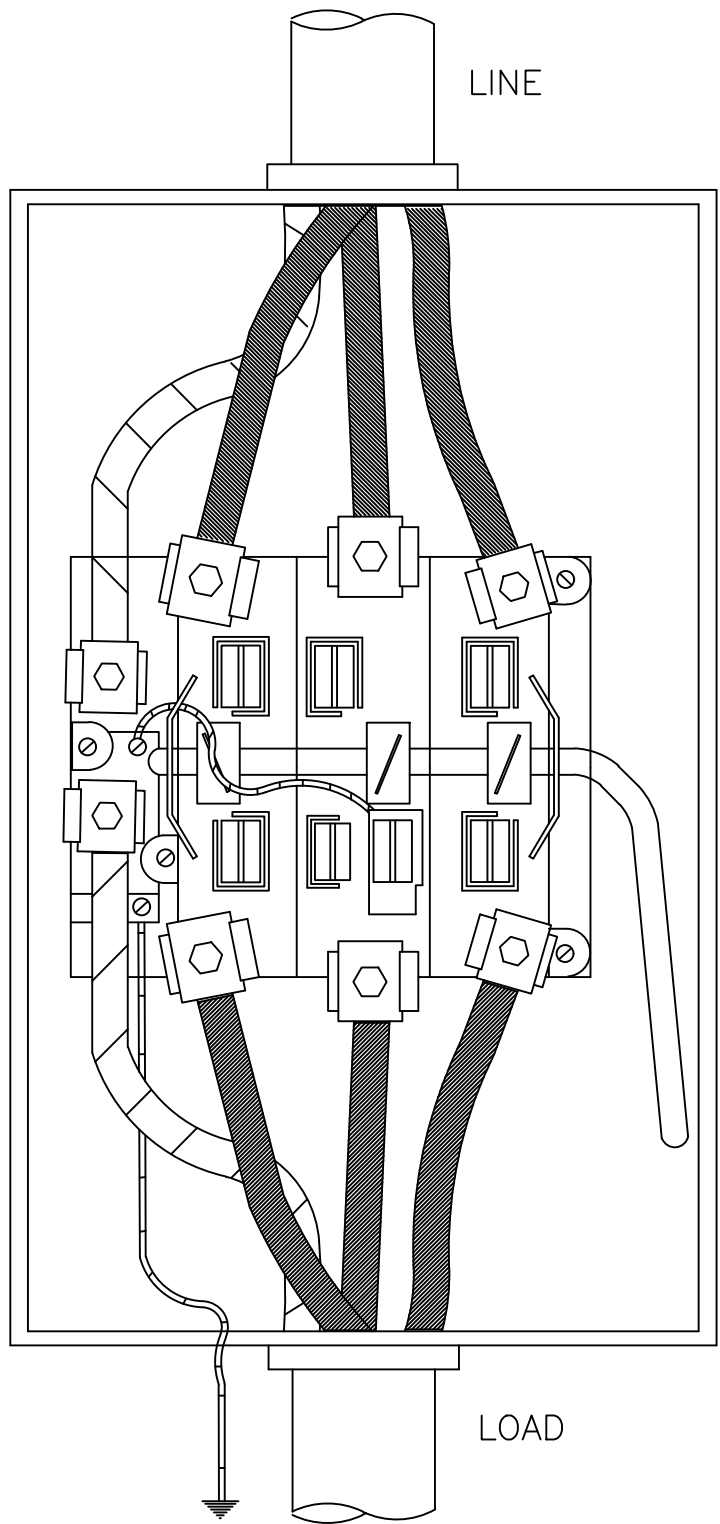

NOTES:

All Meter Cans 480V Phase to Phase require a Main Disconnect on the source side of the meter.

09/30/92	Rev. 10/16/20	Esfing 11.dwg
FOUR WIRE-THREE PHASE METER SOCKET 150 AMP AND ABOVE		
FIGURE 11	CLAY ELECTRIC COOPERATIVE, INC. KEYSTONE HEIGHTS, FLORIDA	STANDARDS FOR ELECTRIC SERVICE

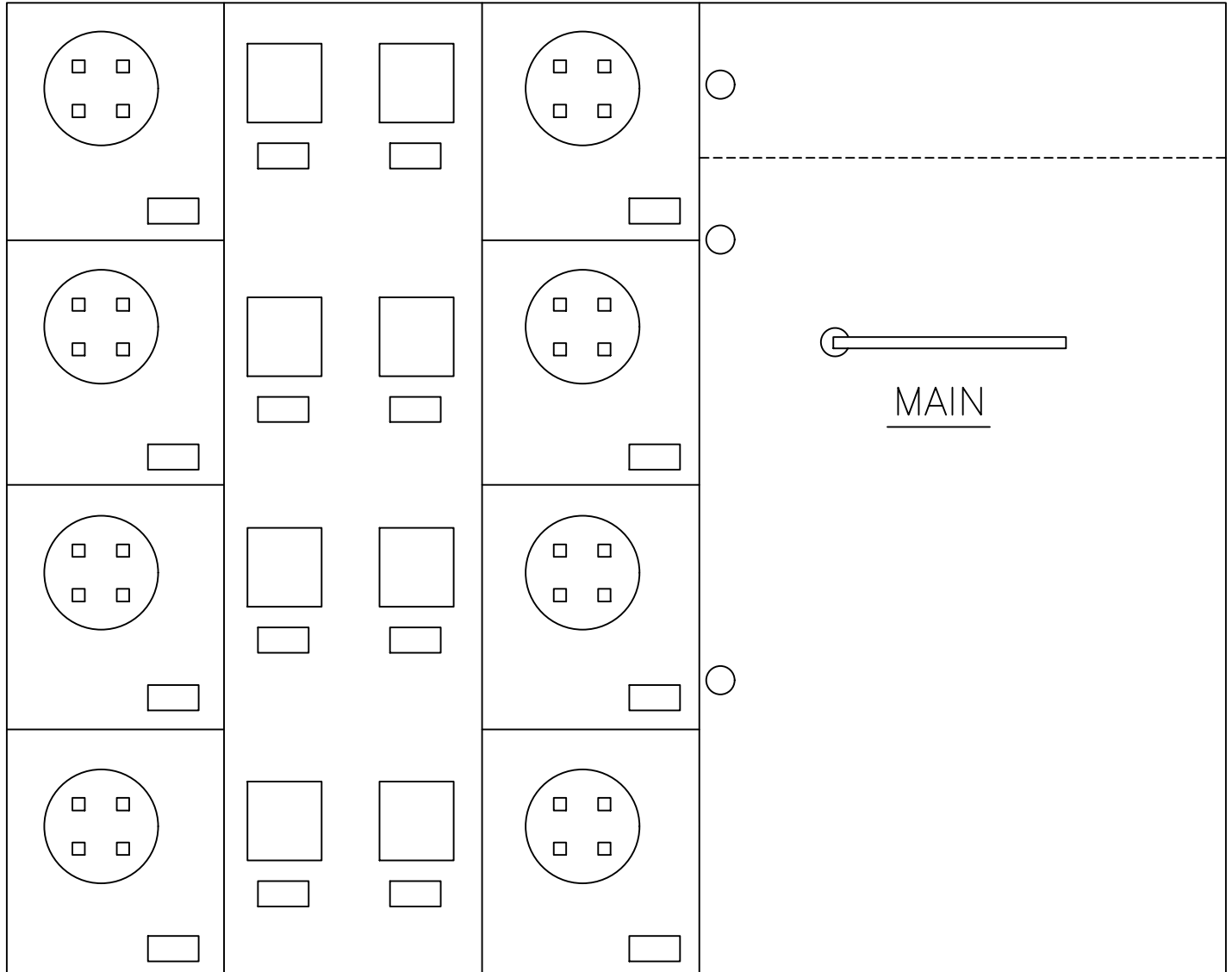

NOTES:

1. METER CENTERS IF USED SHALL BE FURNISHED BY THE MEMBER WITH THE APPROVAL OF THE COOPERATIVE.
2. MAIN DISCONNECTS ARE TO BE LOCKED BY COOPERATIVE.

09/30/92

Rev. 10/20/20

Esf12 2020.dwg

Multi-unit Meter Center

FIGURE 12

CLAY ELECTRIC COOPERATIVE, INC.
KEYSTONE HEIGHTS, FLORIDA

STANDARDS FOR
ELECTRIC SERVICE

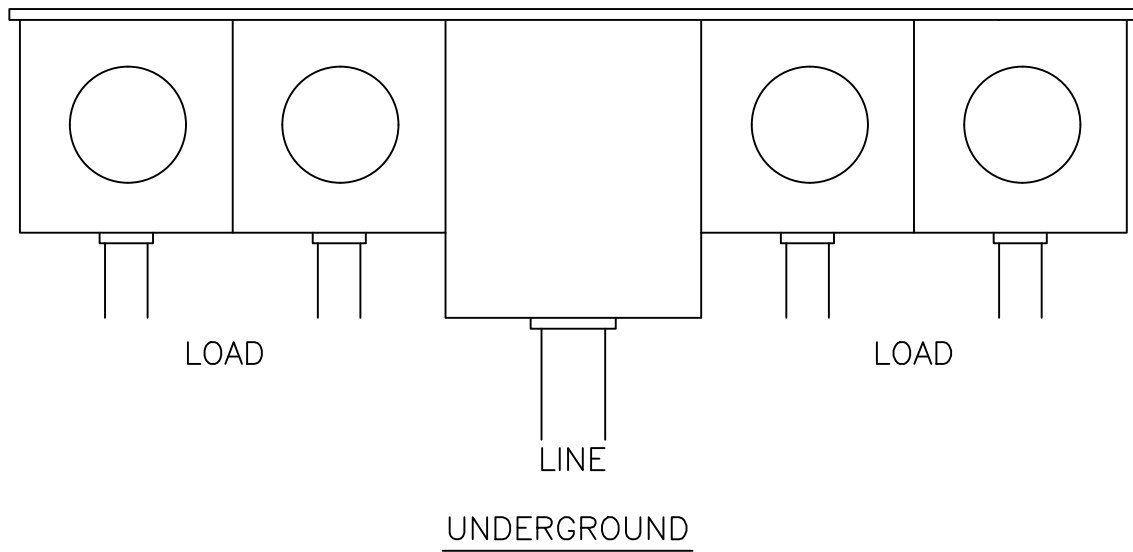
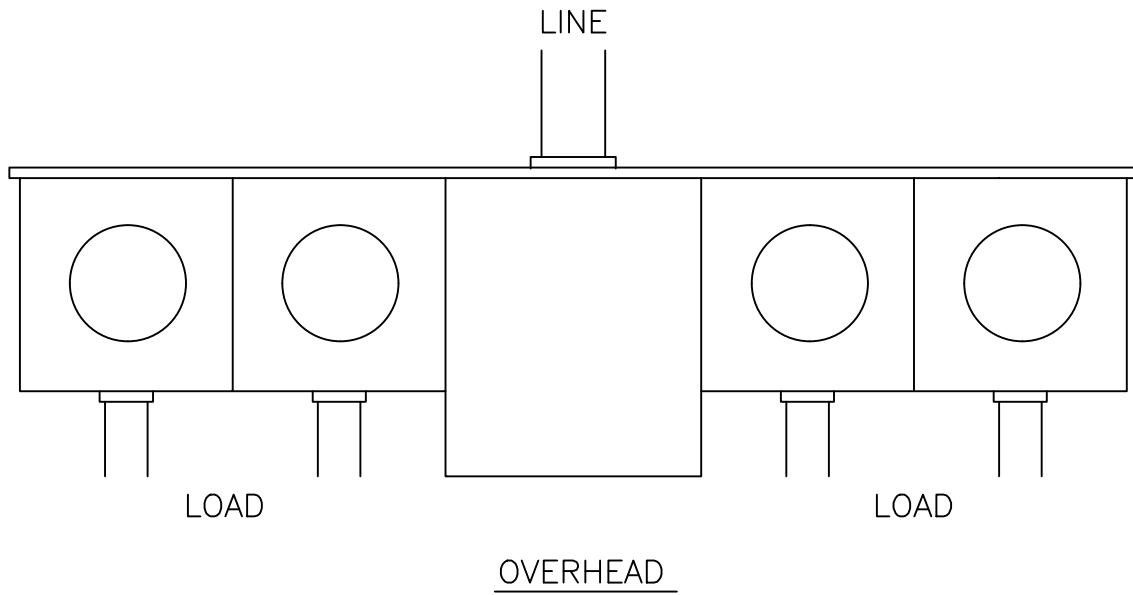

NOTE:

1. GANG METER SOCKETS FURNISHED AND INSTALLED BY THE MEMBER.

09/30/92

Rev. 10/20/20

Esf13 2020.dwg

THREE WIRE SINGLE PHASE GANG INSTALLATION

FIGURE 13

CLAY ELECTRIC COOPERATIVE, INC.
KEYSTONE HEIGHTS, FLORIDA

STANDARDS FOR
ELECTRIC SERVICE

OVERHEAD

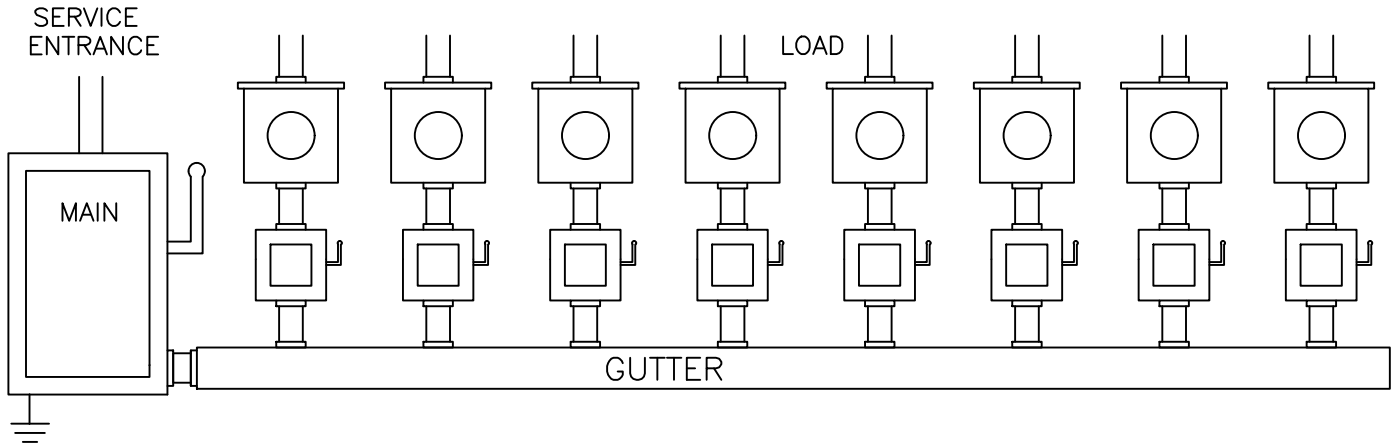

UNDERGROUND

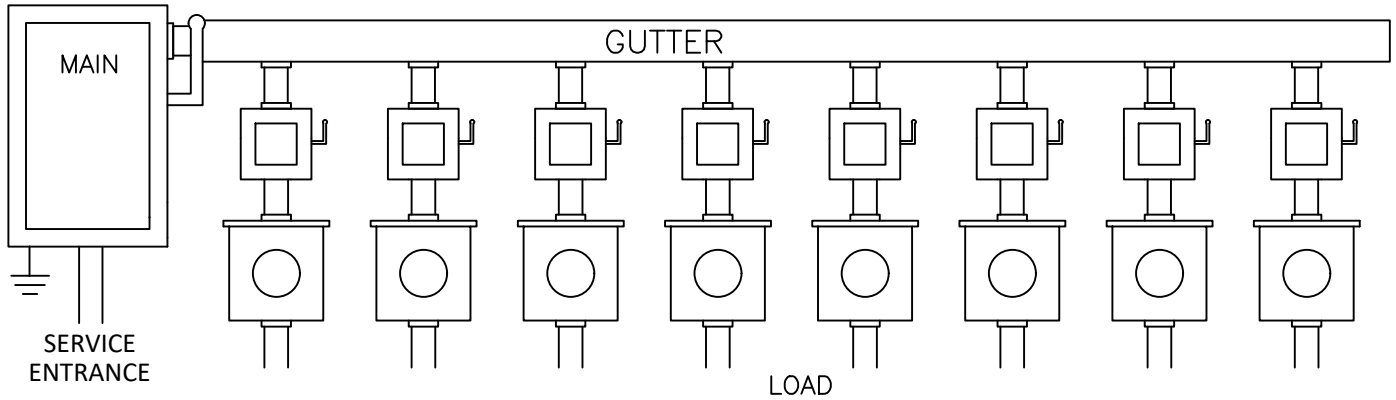

NOTES:

1. METER SOCKETS FURNISHED AND INSTALLED BY THE MEMBER.
2. GUTTER SHALL BE LOCKABLE AND BE SEALED BY COOPERATIVE.
3. **All Meter Cans 480V Phase to Phase require a Main Disconnect on the source side of the meter.**

09/30/92

Rev. 10/20/20

Esf14 2020.dwg

FOUR WIRE THREE PHASE GUTTER INSTALLATION

FIGURE 14

CLAY ELECTRIC COOPERATIVE, INC.
KEYSTONE HEIGHTS, FLORIDA

STANDARDS FOR
ELECTRIC SERVICE

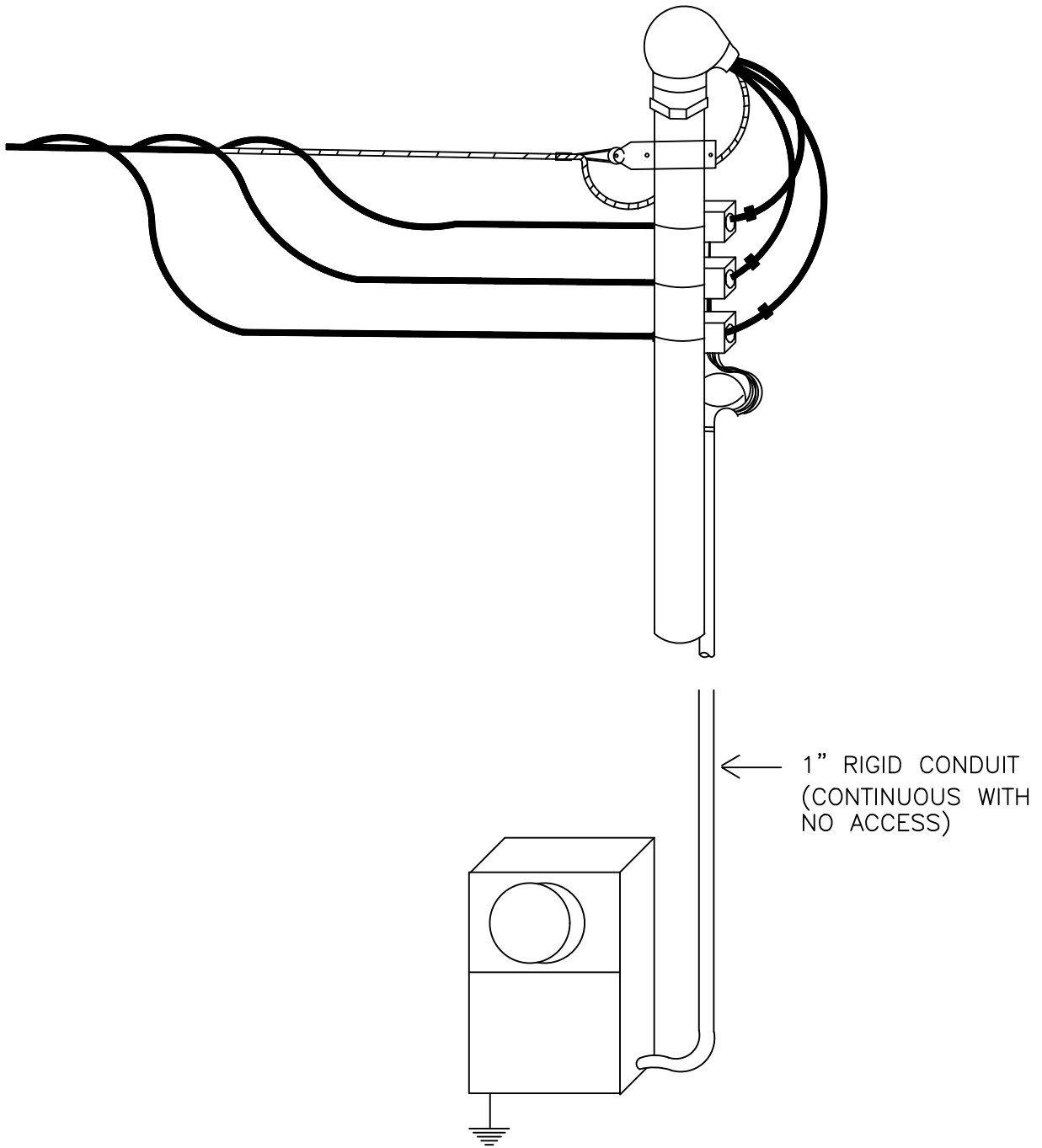

NOTES:
 METER SOCKET AND CT'S TO BE FURNISHED AND INSTALLED BY THE
 COOPERATIVE.

09/30/92

Rev. 12/07/20

Esf15 2020.dwg

FOUR WIRE – 3 PHASE CT INSTALLATION ON MAST ARM

FIGURE 15

CLAY ELECTRIC COOPERATIVE, INC.
 KEYSTONE HEIGHTS, FLORIDA

STANDARDS FOR
 ELECTRIC SERVICE

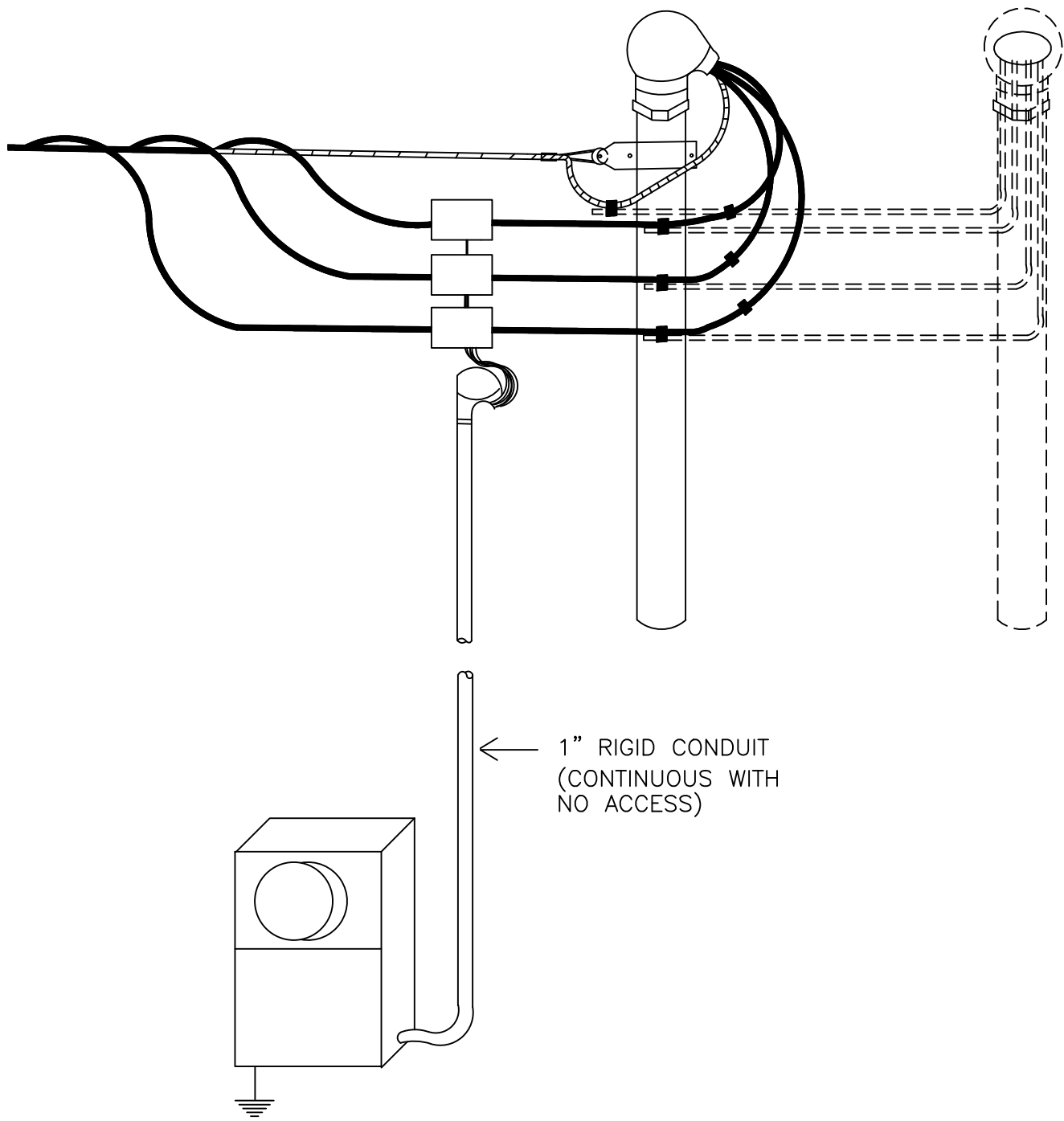

NOTES:

1. METER SOCKET AND CT'S TO BE FURNISHED AND INSTALLED BY THE COOPERATIVE.

09/30/92

Rev. 12/07/20

Esf16 2020.dwg

FOUR WIRE – 3 PHASE CT INSTALLATION ON BRACKET OR WALL

FIGURE 16

CLAY ELECTRIC COOPERATIVE, INC.
KEYSTONE HEIGHTS, FLORIDA

STANDARDS FOR
ELECTRIC SERVICE

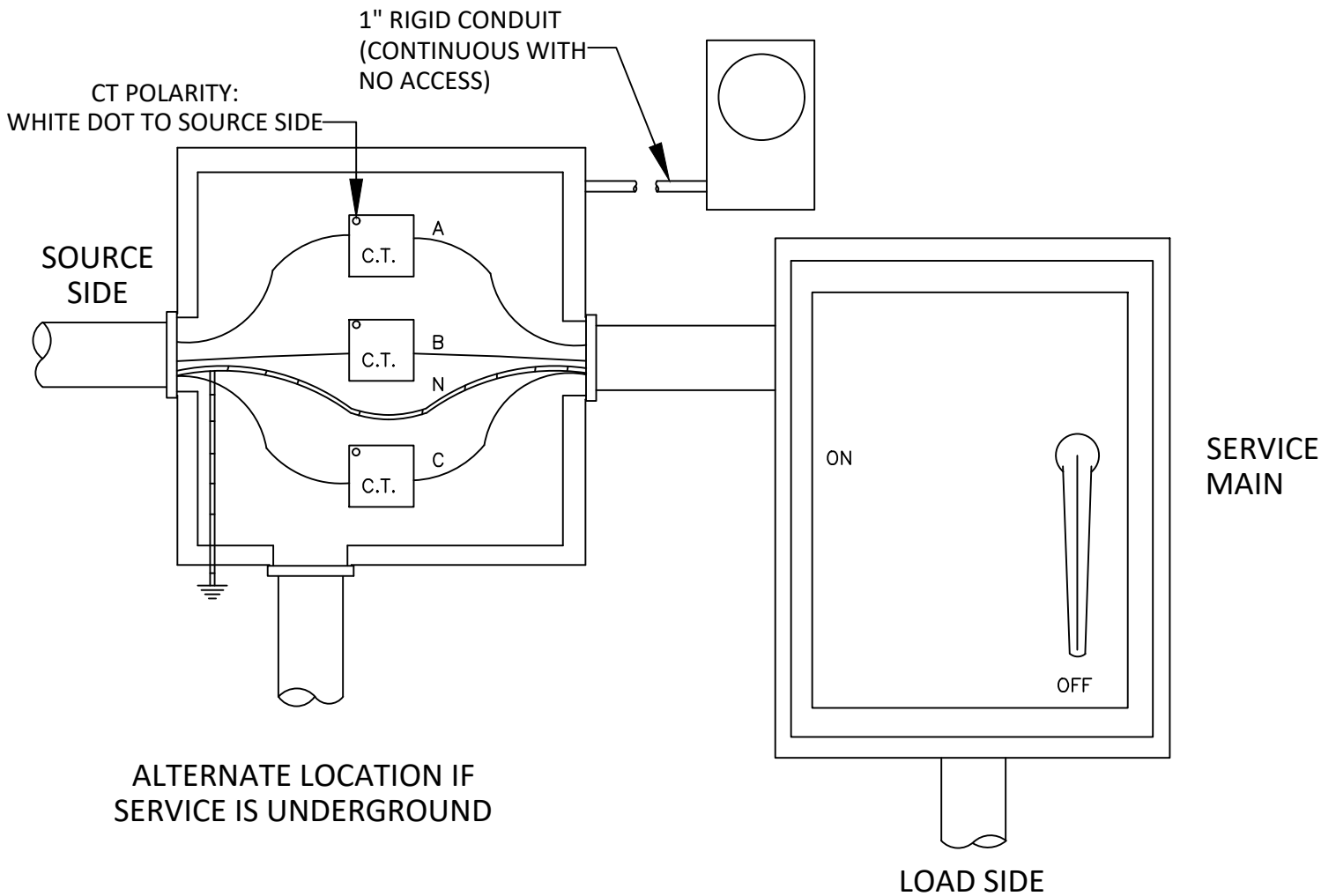

NOTES:

1. METER SOCKET FURNISHED BY THE COOPERATIVE FOR INSTALLATION BY THE MEMBER.
2. METER SHALL BE WITHIN 10' OF THE CT CABINET.
3. CT'S FURNISHED BY THE COOPERATIVE FOR INSTALLATION BY THE MEMBER.
4. CT ENCLOSURE AND DISCONNECT SWITCH FURNISHED AND INSTALLED BY THE MEMBER.
5. ALL CONDUIT TO INCLUDE PULL STRING. THIS INCLUDES CONDUIT FOR CT WIRING TO METER SOCKET. ALL CONDUIT FURNISHED AND INSTALLED BY THE MEMBER.
6. WIRING TO THE LINE SIDE OF DISCONNECT SWITCH, INCLUDING CT WIRING TO BE FURNISHED AND INSTALLED BY COOPERATIVE.
7. 3' MINIMUM HEIGHT TO BOTTOM OF CT ENCLOSURE.
8. REFER TO FIGURE 19 FOR 3-PHASE CT METER ENCLOSURE SPECS.

09/30/92

Rev. 10/20/20

Esf17 2020.dwg

FOUR WIRE THREE PHASE CT INSTALLATION IN ENCLOSURE

FIGURE 17

CLAY ELECTRIC COOPERATIVE, INC.
KEYSTONE HEIGHTS, FLORIDA

STANDARDS FOR
ELECTRIC SERVICE

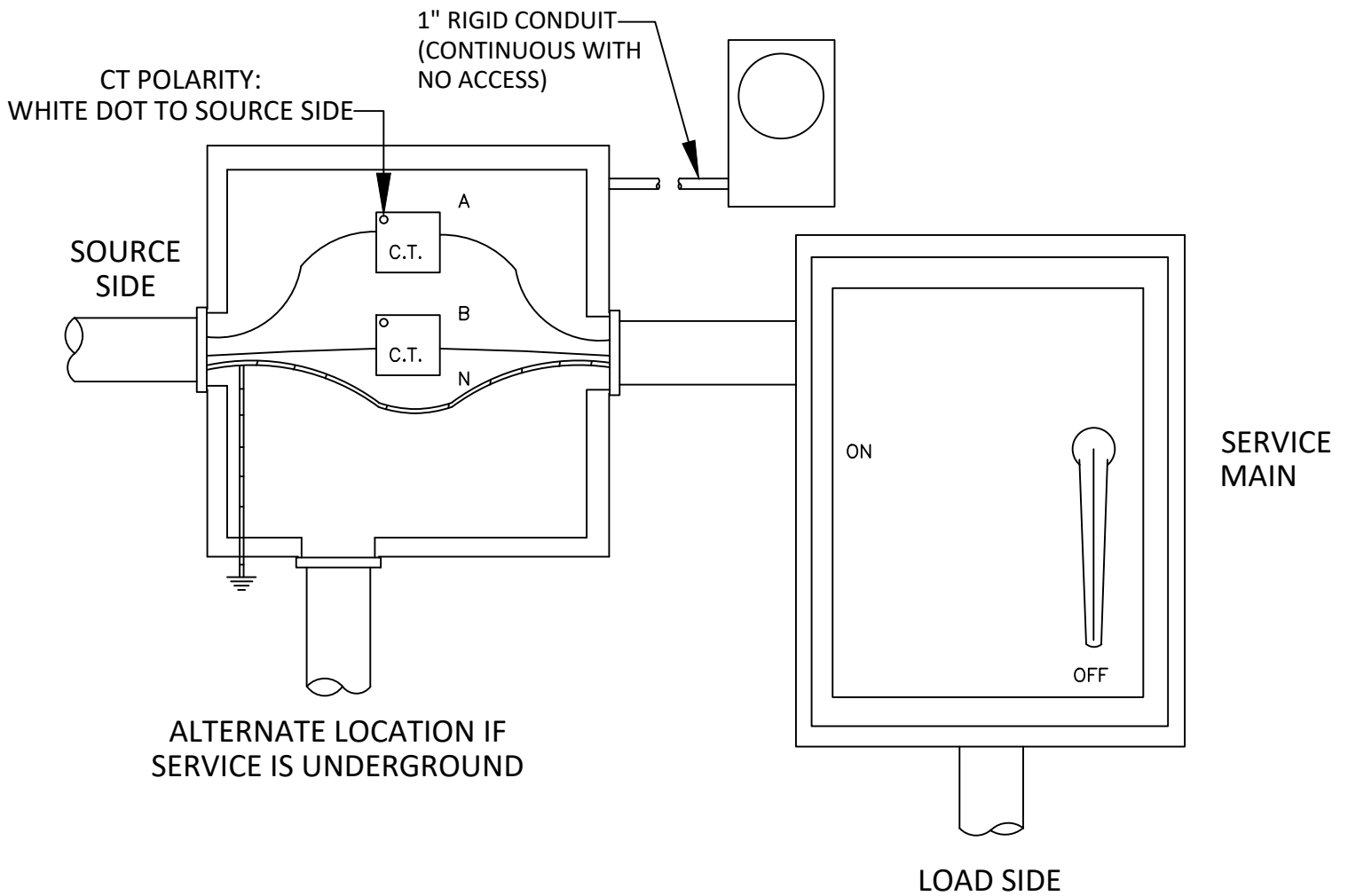

NOTES:

1. METER SOCKET FURNISHED BY THE COOPERATIVE FOR INSTALLATION BY THE MEMBER.
2. METER SHALL BE WITHIN 10' OF THE CT CABINET.
3. CT'S FURNISHED BY THE COOPERATIVE FOR INSTALLATION BY THE MEMBER.
4. CT ENCLOSURE AND DISCONNECT SWITCH FURNISHED AND INSTALLED BY THE MEMBER.
5. ALL CONDUIT TO INCLUDE PULL STRING. THIS INCLUDES CONDUIT FOR CT WIRING TO METER SOCKET. ALL CONDUIT FURNISHED AND INSTALLED BY THE MEMBER.
6. WIRING TO THE LINE SIDE OF DISCONNECT SWITCH, INCLUDING CT WIRING TO BE FURNISHED AND INSTALLED BY COOPERATIVE.
7. 3' MINIMUM HEIGHT TO BOTTOM OF CT ENCLOSURE.
8. REFER TO FIGURE 19A FOR 1 PHASE CT METER ENCLOSURE SPECS.

05/24/01

Rev. 10/20/20

Esf17A 2020.dwg

THREE WIRE SINGLE PHASE CT INSTALLATION IN ENCLOSURE

FIGURE 17A

CLAY ELECTRIC COOPERATIVE, INC.
KEYSTONE HEIGHTS, FLORIDA

STANDARDS FOR
ELECTRIC SERVICE

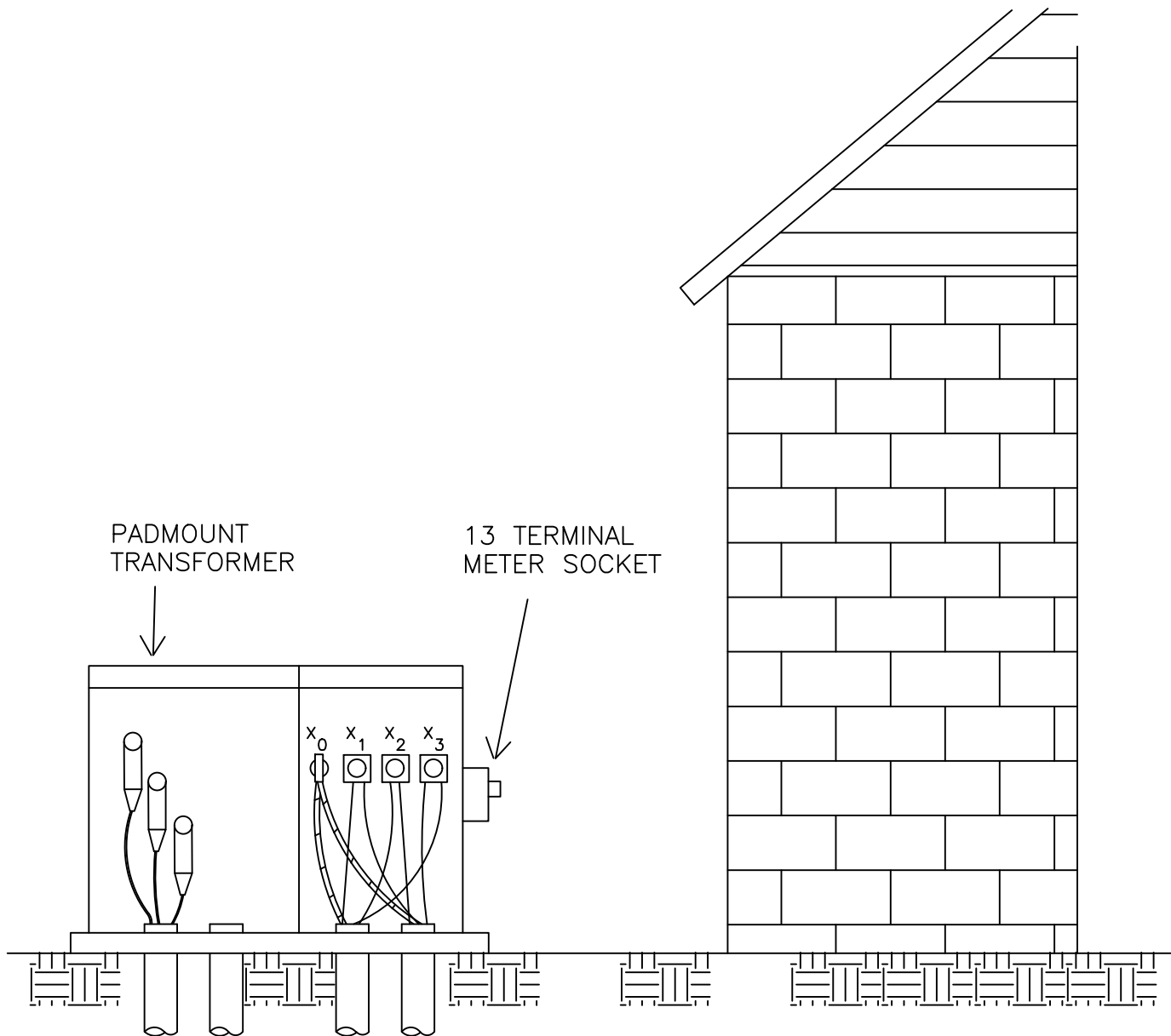

NOTES:

1. TRANSFORMER AND PRIMARY CABLE MUST BE DE-ENERGIZED BY COOPERATIVE BEFORE WORK IS PERFORMED.
2. AT NO TIME IS MEMBER OR THEIR ELECTRICIAN TO WORK INSIDE THE COOPERATIVE'S ENERGIZED TRANSFORMER.
3. INSTALLATION SHALL BE USED WHEN ONLY ONE MEMBER IS SERVED BY THE TRANSFORMER.
4. METER, METER SOCKET, CT'S AND ASSOCIATED WIRING SHALL BE INSTALLED BY THE COOPERATIVE.
5. ALL PRIMARY AND SECONDARY CONDUIT SHALL BE FURNISHED AND INSTALLED BY THE MEMBER.
6. ALL CONDUIT TO INCLUDE PULL STRING.
7. SERVICE CONDUCTORS FROM SECONDARY SIDE OF TRANSFORMER SHALL BE FURNISHED AND INSTALLED, INCLUDING CONNECTIONS, BY THE MEMBER. COOPERATIVE WILL FURNISH ITS' STANDARD CONNECTORS ON TRANSFORMER SECONDARY.

01/25/07

Rev. 10/20/20

Esf18 2020.dwg

FOUR WIRE THREE PHASE CT PADMOUNT TRANSFORMER INSTALLATION

FIGURE 18

CLAY ELECTRIC COOPERATIVE, INC.
KEYSTONE HEIGHTS, FLORIDA

STANDARDS FOR
ELECTRIC SERVICE

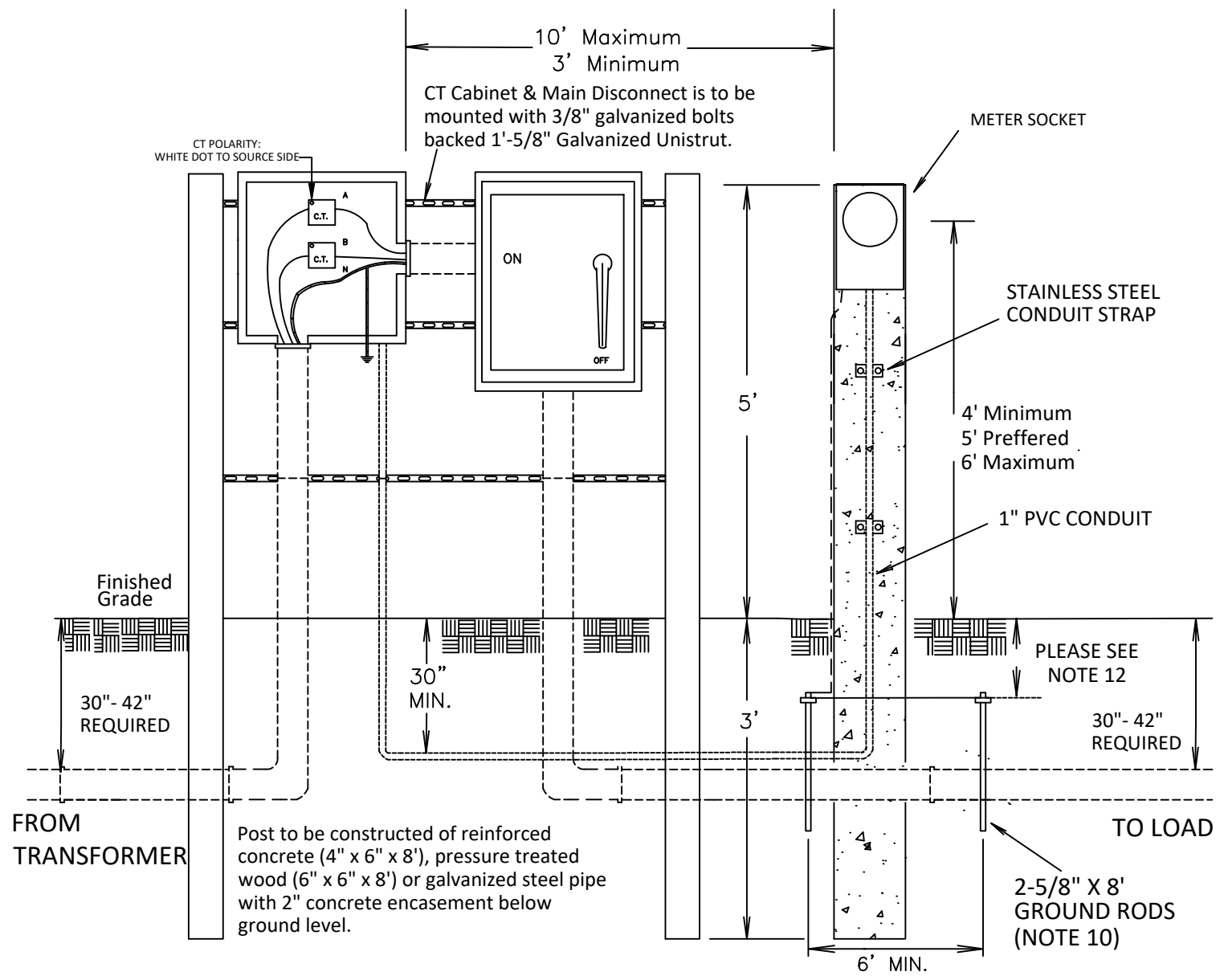

- NOTES:
1. TRANSFORMER AND PRIMARY CABLE MUST BE DE-ENERGIZED BY COOPERATIVE BEFORE WORK IS PERFORMED.
 2. AT NO TIME IS MEMBER OR THEIR ELECTRICIAN TO WORK INSIDE THE COOPERATIVE'S ENERGIZED TRANSFORMER.
 3. INSTALLATION SHALL BE USED WHEN ONLY ONE MEMBER IS SERVED BY THE TRANSFORMER.
 4. METER, CT'S AND ASSOCIATED CT WIRING SHALL BE FURNISHED AND INSTALLED BY THE COOPERATIVE. METER SOCKET FURNISHED BY THE COOPERATIVE FOR INSTALLATION BY THE MEMBER.
 5. ALL PRIMARY, SECONDARY, AND 1" PVC CT CONDUIT SHALL BE FURNISHED AND INSTALLED BY THE MEMBER.
 6. ALL CONDUIT TO INCLUDE PULL STRING.
 7. METER POLE TO BE FURNISHED AND INSTALLED BY THE MEMBER AS SPECIFIED ABOVE
 8. CONCRETE OR FIBERGLASS POST (4"x6"x8' OR 6"x6"x8') BURIAL DEPTH 3'-0" MIN.
 9. CURRENT TRANSFORMERS (CT'S) TO BE FURNISHED AND INSTALLED BY THE COOPERATIVE.
 10. SERVICE CONDUCTORS FROM SECONDARY SIDE OF TRANSFORMER SHALL BE FURNISHED AND INSTALLED, INCLUDING CONNECTIONS, BY THE MEMBER. COOPERATIVE WILL FURNISH ITS' STANDARD CONNECTORS ON TRANSFORMER SECONDARY.
 11. ONE 5/8" X 8' GROUND ROD MAY BE USED IF MEASURED RESISTANCE TO GROUND IS 25 OHMS OR LESS.
 12. THE UPPER END OF THE GROUNDING ROD SHALL BE FLUSH WITH OR BELOW FINISHED GRADE UNLESS THE ABOVE GROUND END AND THE GROUNDING ROD CONDUCTOR ATTACHMENT ARE PROTECTED AGAINST PHYSICAL DAMAGE PER NEC.
 13. MEMBER SHALL ADHERE TO COUNTY CODE REQUIREMENTS IN CONJUNCTION WITH THE NEC.

12/20/17	Rev. 10/21/20	Esf18A 2020.dwg
THREE WIRE SINGLE PHASE CT INSTALLATION AT TRANSFORMER		
FIGURE 18A	CLAY ELECTRIC COOPERATIVE, INC. KEYSTONE HEIGHTS, FLORIDA	STANDARDS FOR ELECTRIC SERVICE

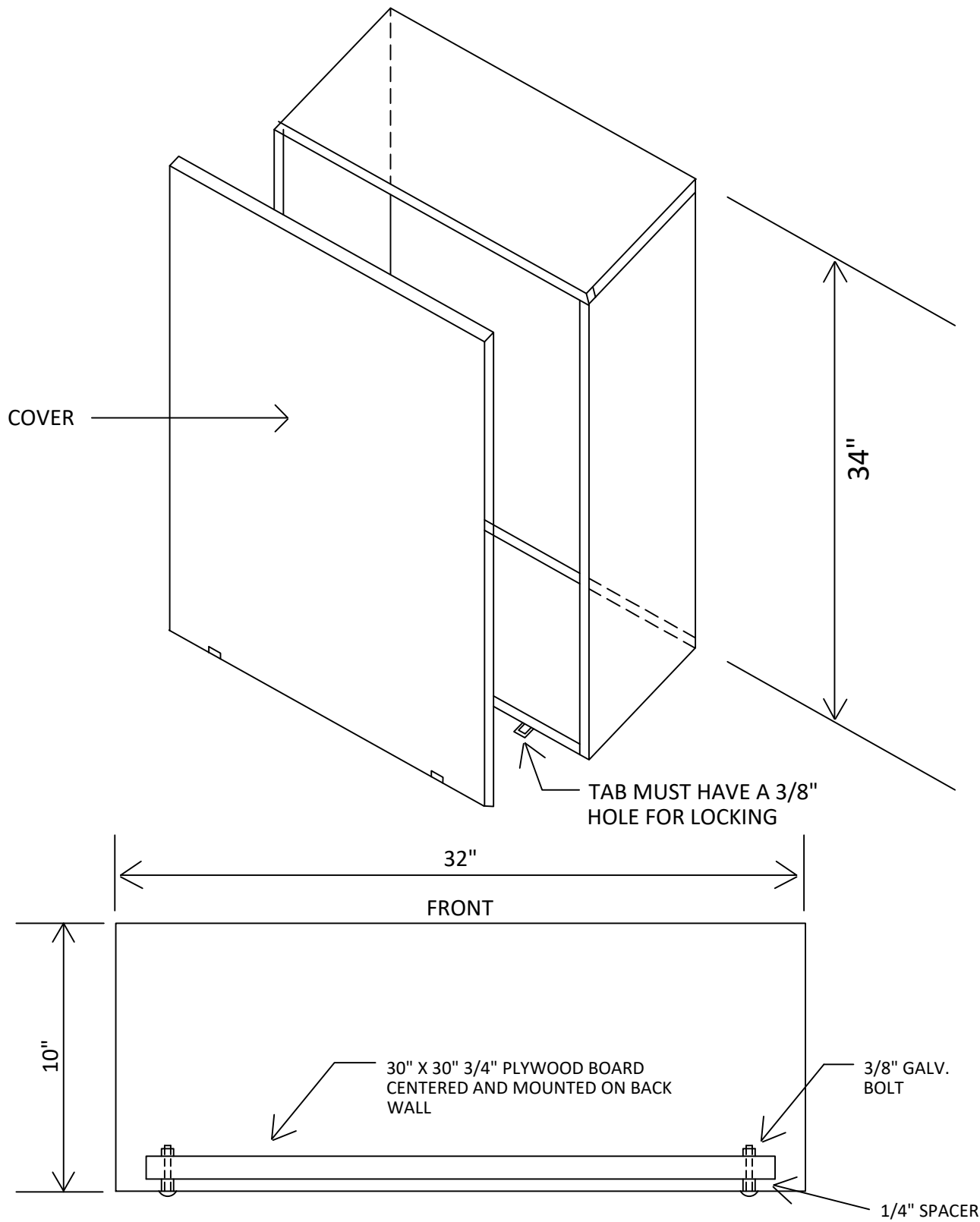

NOTE:

1. CONSTRUCTED OF 16 GAUGE GALVANIZED STEEL OR 14 GAUGE ALUMINUM.

09/30/92	Rev. 10/21/20	Esf19 2020.dwg
C.T. METER ENCLOSURE for 3-PHASE APPLICATIONS		
FIGURE 19	CLAY ELECTRIC COOPERATIVE, INC. KEYSTONE HEIGHTS, FLORIDA	STANDARDS FOR ELECTRIC SERVICE

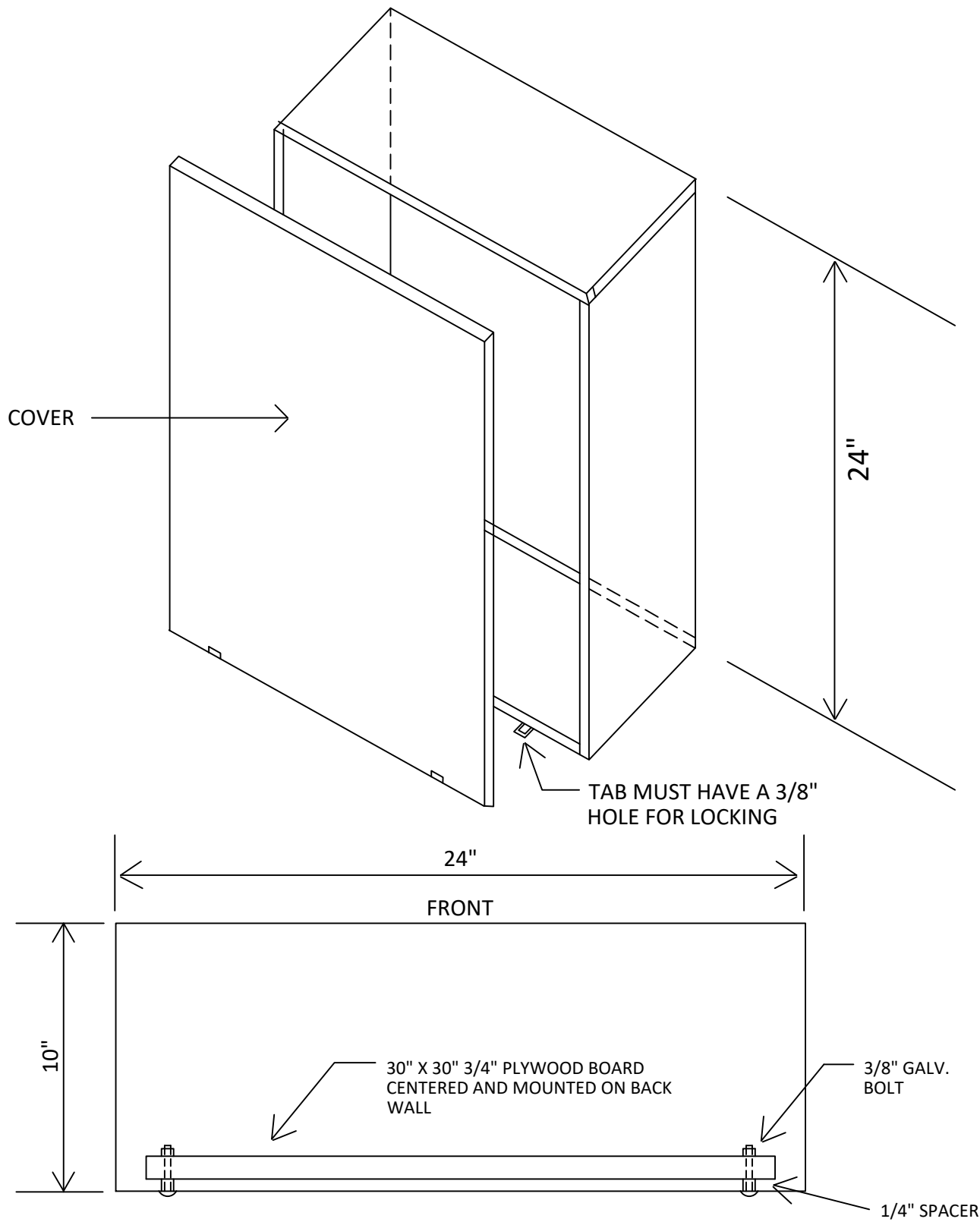

NOTE:

1. CONSTRUCTED OF 16 GAUGE GALVANIZED STEEL OR 14 GAUGE ALUMINUM.

09/30/92	Rev. 10/21/20	Esf19A 2020.dwg
C.T. METER ENCLOSURE for 1-PHASE APPLICATIONS		
FIGURE 19A	CLAY ELECTRIC COOPERATIVE, INC. KEYSTONE HEIGHTS, FLORIDA	STANDARDS FOR ELECTRIC SERVICE

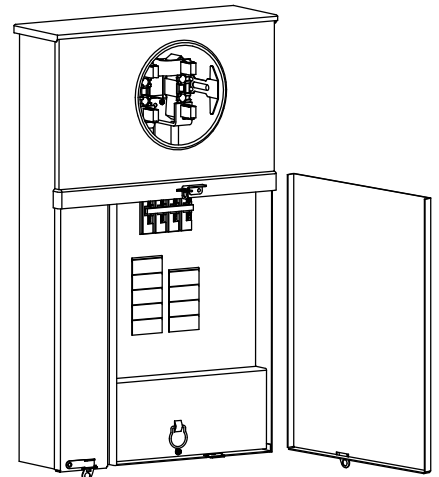
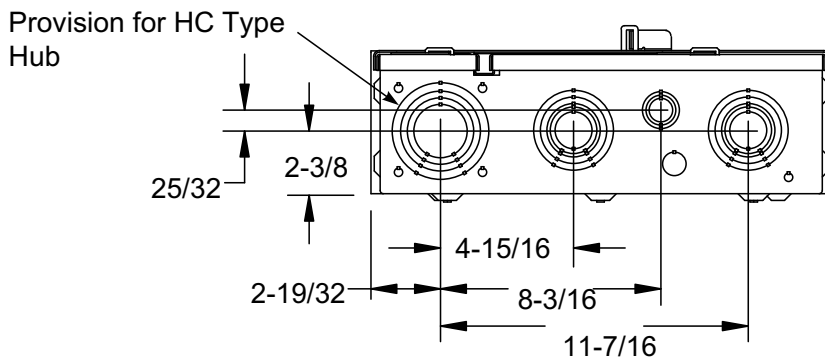
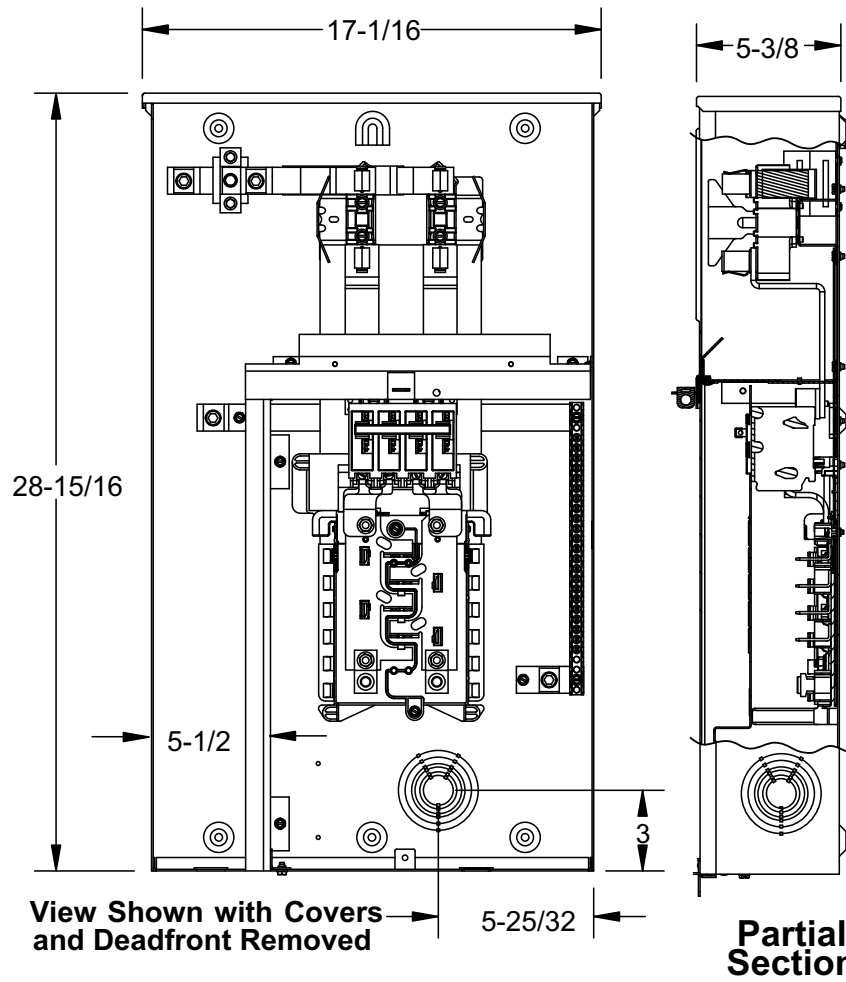

Approved Manufacturers:
Siemens MC0816B1200RTD or Equivalent
Contact CEC Engineering for approvals.

10/21/20

Esfig20 2020.dwg

Vertical Combo Meter Enclosure

Figure 20

CLAY ELECTRIC COOPERATIVE, INC.
 KEYSTONE HEIGHTS, FLORIDA

STANDARDS FOR
 ELECTRIC SERVICE

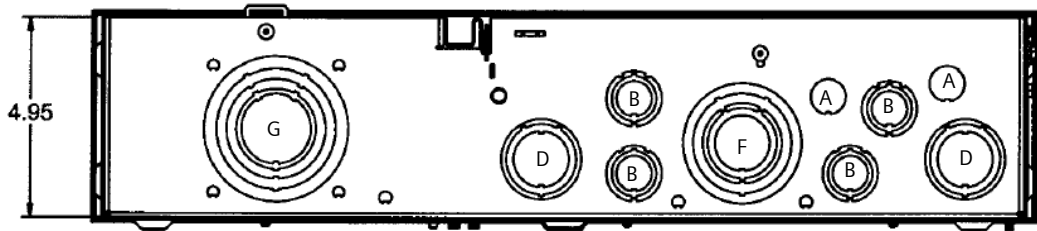
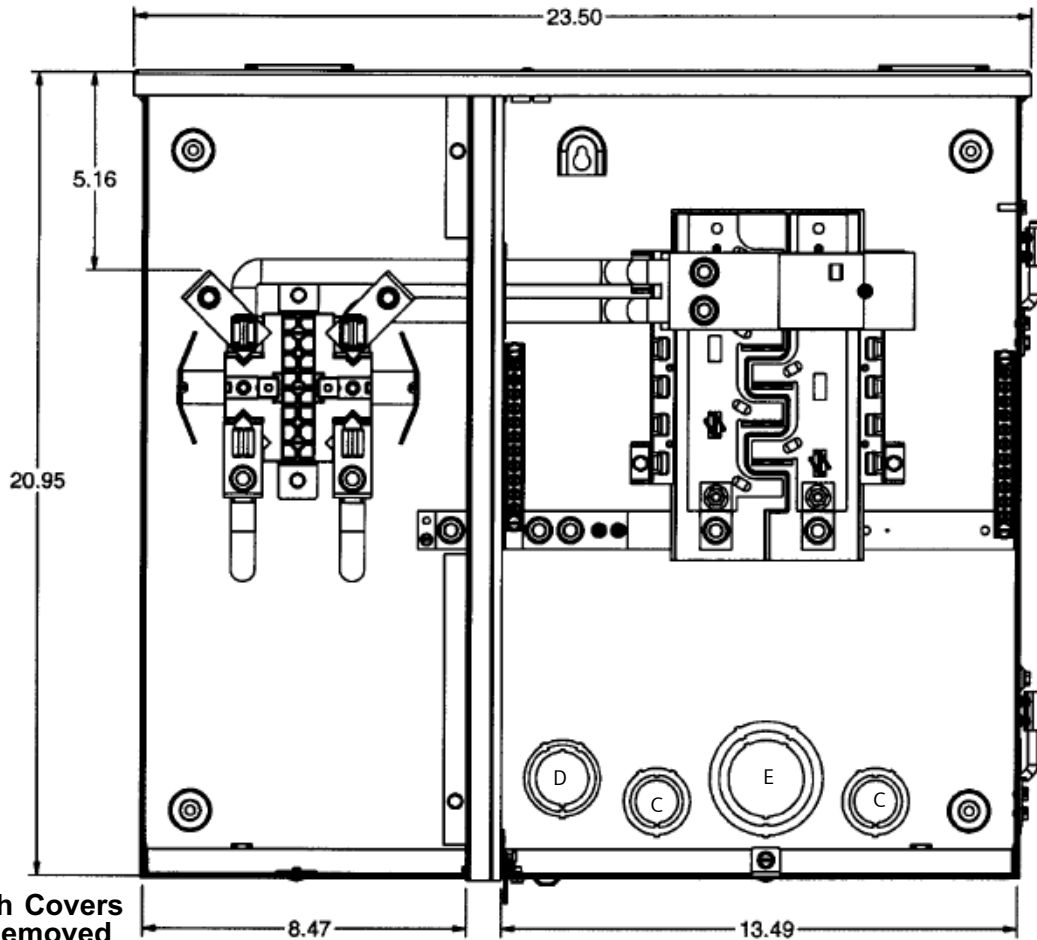

Knockout Code Chart

- A = 1/2"
- B = 1/2", 3/4", 1"
- C = 3/4", 1", 1-1/4"
- D = 1, 1-1/4", 1-1/2"
- E = 1-1/2", 2", 2-1/2"
- F = 1", 1-1/4", 1-1/2", 2", 2-1/2"
- G = 1-1/4", 1-1/2", 2", 2-1/2", 3"

Features

- CEC Locking Tabs Required
- Underground feed
- Feed Thru Lugs

NOTES:

1. All 320A meter sockets shall be equipped with a bypass handle.

Approved Manufacturers:

Siemens MC0816B1150-200TH or Equivalent
Contact CEC Engineering for approvals.

For 320A or above:

Siemens MC0816B1400RLTM or equivalent
Contact CEC Engineering for approvals.

02/12/2021

Esf21 2020.dwg

Side-By-Side Combo Meter Enclosure

FIGURE 21

CLAY ELECTRIC COOPERATIVE, INC.
 KEYSTONE HEIGHTS, FLORIDA

STANDARDS FOR
 ELECTRIC SERVICE

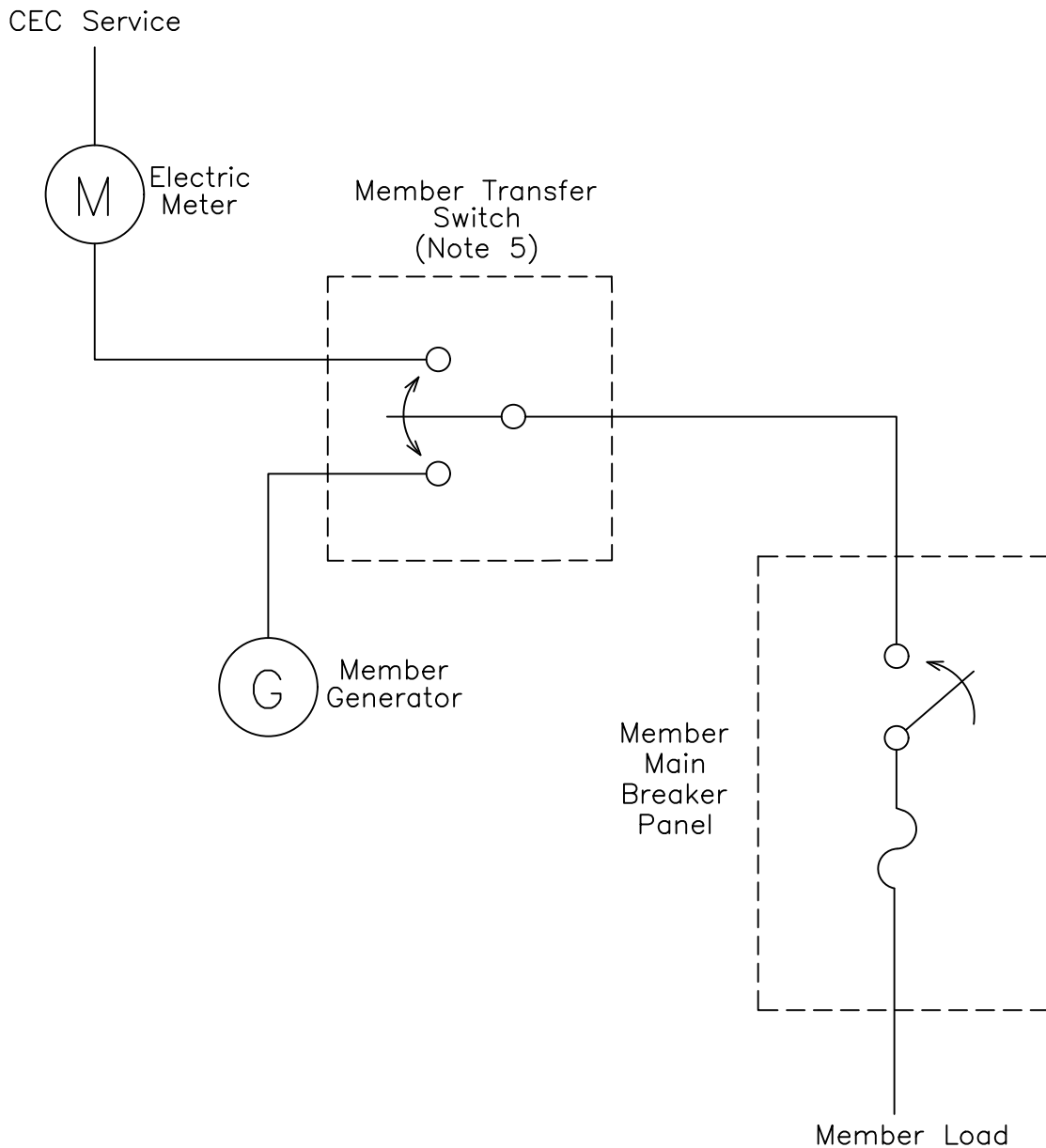

Improperly installed generation equipment can create hazards for CEC personnel, the member and the electrical equipment involved. To prevent these hazards the following notes shall be followed:

- Notes:
1. Emergency or standby generation systems installed by the member shall have a switching control scheme or a mechanically interlocked transfer switch as to eliminate the possibility of any energy generated by the member's system being back-fed into the Cooperative's system.
 2. Emergency or standby generation systems shall be in compliance with the National Electric Code and local codes.
 3. Such generation systems and their associated equipment shall be installed by a Licensed Electrician.
 4. Member Owned Generators of the Standards for Electric Service shall be adhered to for installations of this type.(Section 8.04)
 5. Double Throw (Not Fuseable) Mechanically Interlocked Transfer Switch: For Typical Single Phase, 240VAC, 200 Amp Service

08/14/99

Rev. 10/21/20

Esf22 2020.dwg

MEMBER OWNED GENERATORS: TYPICAL INSTALLATION

FIGURE 22

CLAY ELECTRIC COOPERATIVE, INC.
KEYSTONE HEIGHTS, FLORIDA

STANDARDS FOR
ELECTRIC SERVICE

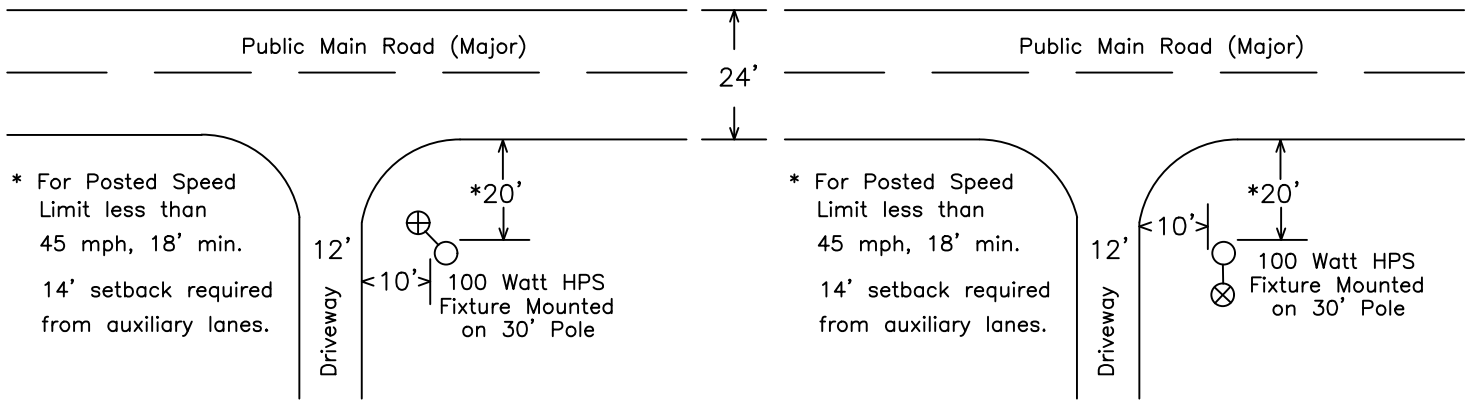

Application "A"

For pole that is within FDOT or County ROW. Permitting will be required unless light is turned directly toward private property (refer to Application "B").

Application "B"

For pole within ROW, permitting not required if light directed toward private property as shown above.

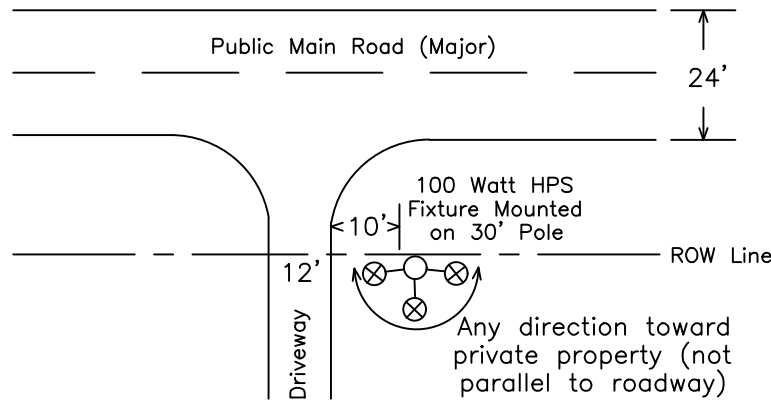

Application "C"

For pole on private property, light may be directed toward private property in any direction. Light should not be directed toward roadway without considering permit requirements.

Private Driveway to Residence onto Public Roadway (Application A, B & C):

1. Lighting levels are not specified for lighting single family driveways onto public roadways (low traffic volume at miniature intersection).
2. The 100 watt light may be placed on either side of the driveway. Refer to application type for lighting direction and permitting requirement.
3. Applications "B" & "C" may be applied for lighting requests without driveways.
4. When submitting permit applications, the CEC Public Roadway Services Utility Permit Attachment "A" shall be attached.
5. *Horizontal Clearances listed are for rural roadways (flush shoulders). For urban roadways (curb & gutter), the minimum setback shall be four (4') feet from back of curb face. Ten (10') feet recommended setback from driveway.

04/08/05

Rev. 10/21/20

Esfig23 2020.dwg

GUIDELINE FOR LIGHTING DRIVEWAY ONTO PUBLIC ROADS

FIGURE 23

CLAY ELECTRIC COOPERATIVE, INC.
KEYSTONE HEIGHTS, FLORIDA

STANDARDS FOR
ELECTRIC SERVICE

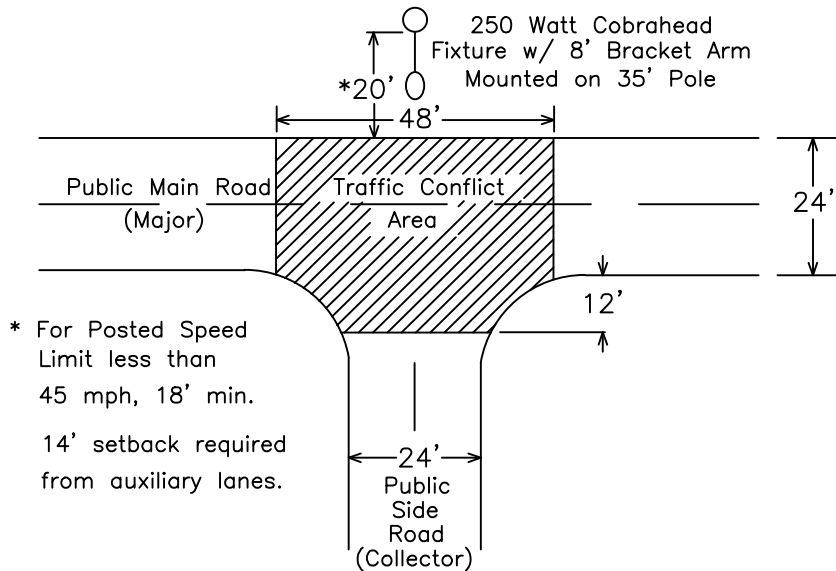

Arrangement "A"

Traffic Volume < 3000 vehicles per Day

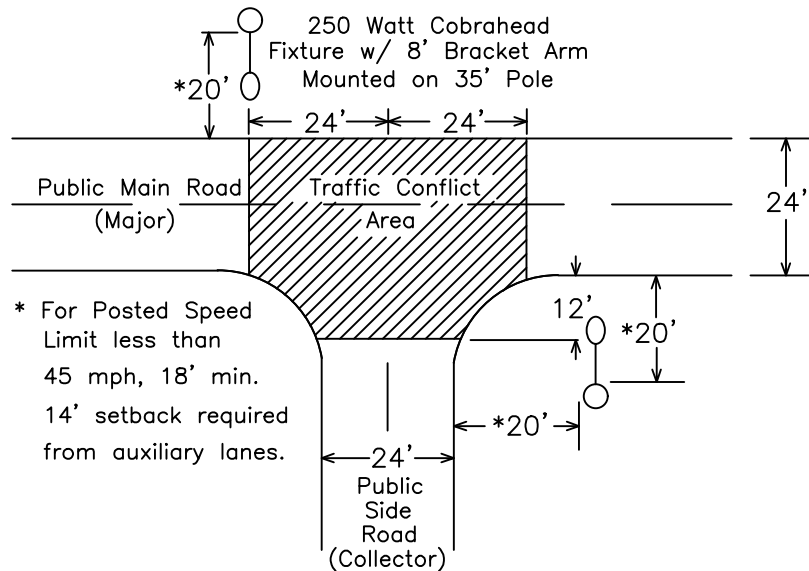

Arrangement "B"

Traffic Volume > 3000 vehicles per Day

NOTES: T-Intersection of Two Public Roadways (Major/Major)

1. An average foot-candle value of 1.8 is anticipated within the Traffic Conflict Area shown for Arrangement "A"; average foot-candle value of 2.9 is anticipated for arrangement "B". Note traffic volume values for each lighting arrangement.
2. Required permitting will need to be granted from the appropriate roadway agency prior to installing lighting within the public roadway. The CEC Public Roadway Lighting Services Utility Permit Attachment "A" shall be attached to the permit applications.
3. *Horizontal Clearances listed above are for Rural roadways (flush shoulders). For Urban roadways (curb and gutter), the minimum setback shall be four (4') feet from back of face of curb.

04/08/05

Rev. 10/21/20

Esfig24 2020.dwg

GUIDELINE FOR LIGHTING T-INTERSECTION OF TWO PUBLIC ROADS

FIGURE 24

CLAY ELECTRIC COOPERATIVE, INC.
KEYSTONE HEIGHTS, FLORIDA

STANDARDS FOR
ELECTRIC SERVICE

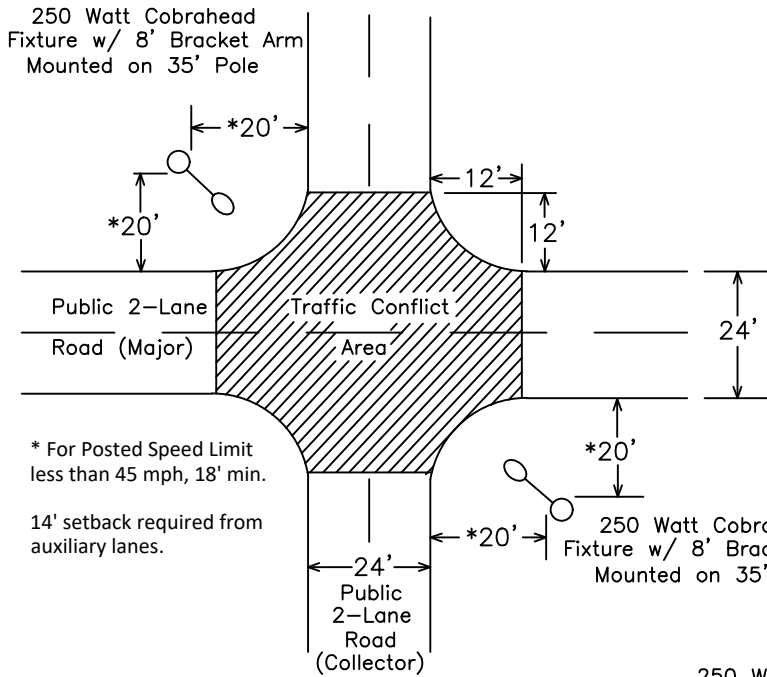

Arrangement "A"
Traffic Volume < 3000 vehicles per day

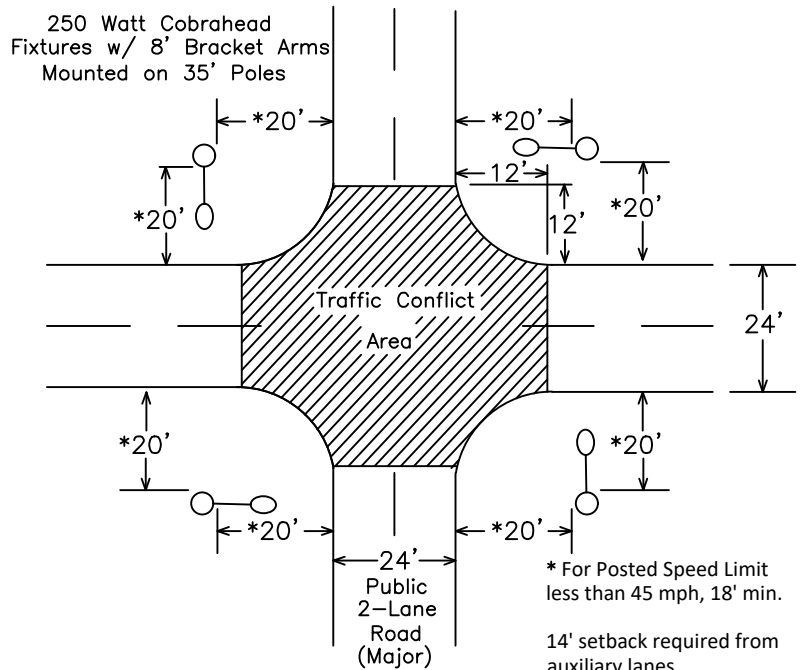

Arrangement "B"
Traffic Volume > 3000 vehicles per day

NOTES: Four-Way Intersection of Two Public Roadways

1. An average footcandle value of 2.3 is anticipated within the Traffic Conflict Area shown for Arrangement "A"; average footcandle value of 5.0 is anticipated for Arrangement "B". Note traffic volume for each lighting arrangement.
2. Required permitting will need to be granted from the appropriate roadway agency prior to installing lighting within the public roadway. The CEC Public Roadway Lighting Services Utility Permit Attachment "A" shall be attached to the permit applications.
3. *Horizontal Clearances listed above are for Rural roadways (flush shoulders). For Urban roadways (curb and gutter), the minimum setback shall be four (4') feet from back of face of curb.

04/08/05

Rev. 10/21/20

Esfig25 2020.dwg

GUIDELINE FOR LIGHTING INTERSECTION OF TWO PUBLIC ROADS

FIGURE 25

CLAY ELECTRIC COOPERATIVE, INC.
KEYSTONE HEIGHTS, FLORIDA

STANDARDS FOR
ELECTRIC SERVICE

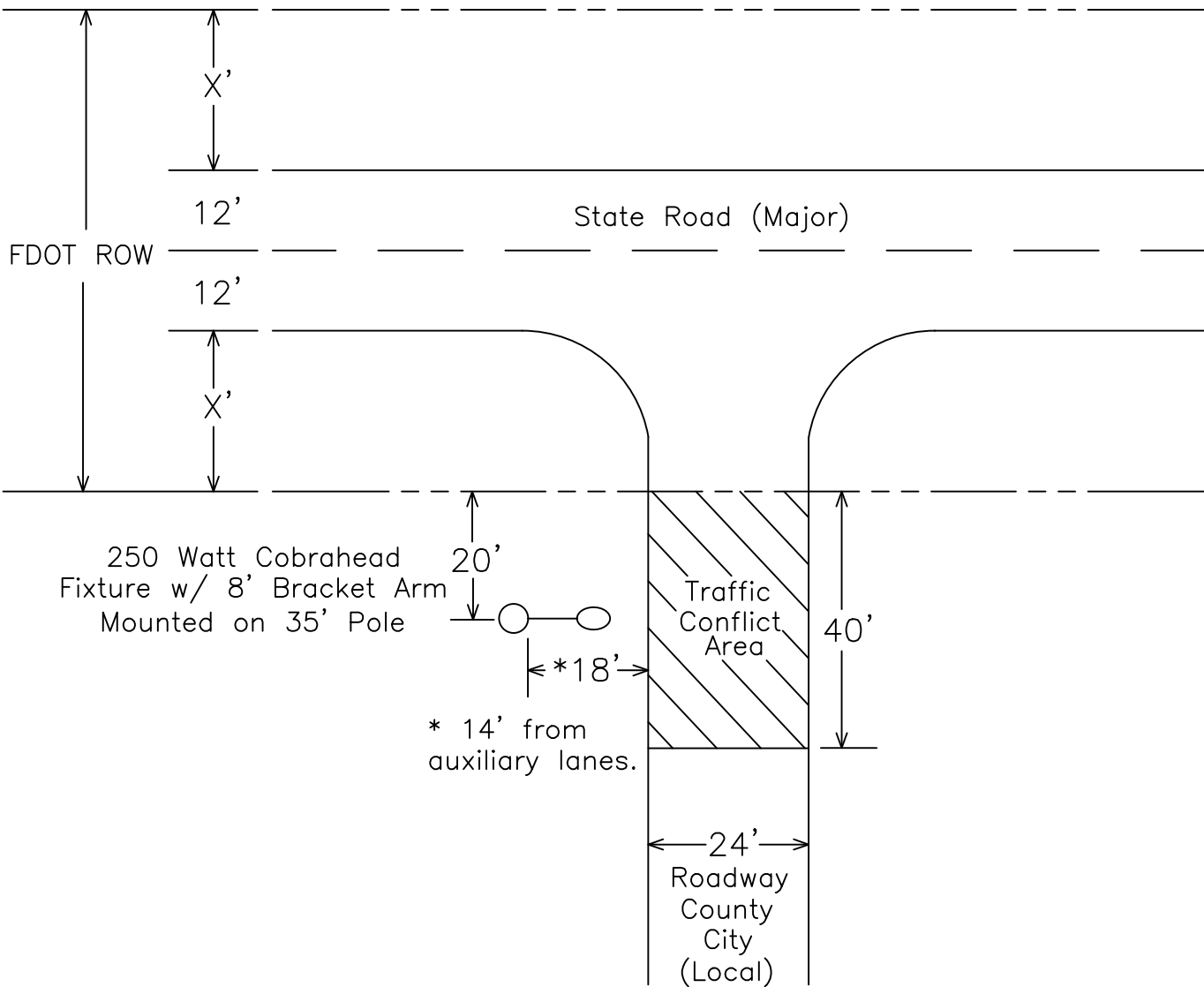

NOTES: Bus Stop/Cross Walk Located in Mid-block or near Intersection (Major/ Local):

1. Applicable for posted speed limit of less than 45 MPH for minimum setback of 18' from the edge of pavement (or travel lane line) to the pole face. Lighting pole shall be a minimum of 20' from FDOT ROW line.
2. For bus stops, the lighting pole shall be installed approximately ten (10') feet beyond the point in front of the bus when loading and unloading.
3. An average foot-candle value of 2.4 is anticipated within the forty (40') feet long "traffic conflict area" on a 24' wide two-lane roadway.
4. Permitting will need to be granted from the "local" roadway agency prior to installing lighting within the public roadway. The CEC Public Roadway Lighting Services Utility Permit Attachment "A" shall be attached to the permit application.

04/08/05

Rev. 10/21/20

Esf26 2020.dwg

GUIDELINE FOR LIGHTING AT BUS STOPS & CROSSWALKS

FIGURE 26

CLAY ELECTRIC COOPERATIVE, INC.
KEYSTONE HEIGHTS, FLORIDA

STANDARDS FOR
ELECTRIC SERVICE

**CLAY ELECTRIC COOPERATIVE, INC. DISCLAIMER AND HOLD HARMLESS
AGREEMENT FOR THE INSTALLATION OF ELECTRIC FACILITIES**

The undersigned Consumer has requested that Clay Electric Cooperative, Inc. (Clay) install an electric meter at the Consumer's premises for the purpose of providing electric service to Consumer's _____

Description of Consumer's Property/Building

Consumer acknowledges that Florida Statute §553.73(10)(c) exempts nonresidential farm buildings from the Florida Building Code and has advised Clay that inspection of the electric wiring is not required by the local county government.

The following definitions apply to this disclaimer:

Consumer's Facilities means all wiring and other related electric facilities that exist between Clay's meter and all parts of the Consumer's building or other exempt agricultural applications.

Clay means Clay Electric Cooperative, Inc., an electric utility.

Consumer means the property owner or other proper applicant requesting electric service from Clay who has signed this form.

By signing below, I acknowledge that Clay will be installing or has installed an electric meter at my request to provide electric service to Consumer's Facilities. I acknowledge that Clay is responsible only for the electric meter and that Consumer's Facilities are entirely my responsibility.

By signing below, I acknowledge that Clay has not inspected Consumer's Facilities nor has Clay rendered any opinion whatsoever on Consumer's Facilities. I understand that Clay recommends that I have these facilities inspected even though these facilities are exempted from inspection requirements. I further acknowledge that Clay disclaims any liability or responsibility for anything that has been or will be done in relation to Consumer's Facilities.

By signing below, I agree to defend, indemnify, and hold harmless Clay from any liability, loss, damage, injury, claim, and attorney's fees incurred by Clay or asserted against Clay relating to any such liability to persons or property caused by Consumer's Facilities. I waive and release Clay from any claim I may have related to any loss caused to me by Consumer's Facilities. I further agree that I am responsible for any injury or damage caused to Clay, its facilities, or its agents by Consumer's Facilities.

In witness whereof, this agreement is executed by Consumer this _____ day of _____, 20 _____

Signature of Consumer

Signature of Witness

Print Name: _____

Print Name: _____

Address: _____

Address: _____

Phone Number: _____

Phone Number: _____

Company: _____

Title: _____